

**Questions from April 2004 Physics 111.6 Final Exam**

- A1.** A hiker walks 3 km West, then turns and walks 4 km North. The hiker's straight-line distance from her starting point is
- (A) 7 km.      (B) 5 km.      (C) 4 km.      (D) 3 km.      (E) 1 km.
- A2.** Two cars are travelling in straight line motion on a highway. Both cars are accelerating in the same direction, and the magnitude of the acceleration of the first car is greater than the magnitude of the acceleration of the second car. Which one of the following statements is correct?
- (A) The velocity of the first car must always be greater than the velocity of the second car.  
(B) The velocity of the second car must always be greater than the velocity of the first car.  
(C) In the same time interval, the velocity of the first car changes more than the velocity of the second car.  
(D) In the same time interval, the velocity of the second car changes more than the velocity of the first car.  
(E) In the same time interval, the average velocity of the first car must be the same as the average velocity of the second car.
- A3.** A ball is thrown vertically upward. Consider the motion of the ball from the instant it leaves the person's hand until just before it hits the ground, and ignore any effects due to air resistance. Choosing UP to be the positive direction, which of the following statements is correct concerning the acceleration of the ball?
- (A) The acceleration of the ball is 0 at the top of its trajectory.  
(B) The acceleration is  $+g$  throughout the ball's motion.  
(C) The acceleration is  $-g$  throughout the ball's motion.  
(D) The acceleration is  $+g$  when the ball is moving upward and  $-g$  when the ball is moving downward.  
(E) The acceleration is  $-g$  when the ball is moving upward and  $+g$  when the ball is moving downward.
- A4.** A crate of mass  $m$  is sliding down a ramp that is inclined at an angle of  $\theta$  above the horizontal. The acceleration of the crate is  $a$ . The normal force acting on the crate is
- (A)  $ma$ .  
(B)  $mg$ .  
(C)  $mg \cos \theta$ .  
(D)  $mg \sin \theta$ .  
(E)  $m(g \cos \theta - a)$ .
- A5.** A satellite of mass  $m$  is in a stable circular orbit at a height  $h$  above the surface of the Earth (mass  $M_E$ , radius  $R_E$ ). The speed of the satellite does **not** depend on
- (A)  $m$ .      (B)  $M_E$ .      (C)  $G$ .      (D)  $h$ .      (E)  $R_E$ .

- A6.** An airplane flying south makes a turn toward the east while maintaining constant speed. Which one of the following statements is correct?
- (A) During the turn the acceleration of the plane is zero.
  - (B) During the turn the angular acceleration of the plane is zero.
  - (C) During the turn the angular velocity of the plane is zero.
  - (D) During the turn the directions of the acceleration vector and of the tangential velocity vector are parallel.
  - (E) During the turn the centripetal acceleration of the plane is zero.

- A7.** A string is tied to a mass  $m$ . The string is then wrapped around the rim of a pulley of mass  $M$  and radius  $R$ . The pulley is mounted on an axle so that its axis of rotation is horizontal. Ignore any frictional effects between the pulley and the axle. When the mass is released, it

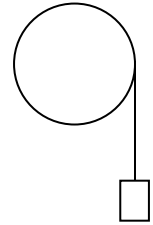

- (A) remains at rest.
  - (B) has a downward acceleration of magnitude  $g$ .
  - (C) has a downward acceleration of magnitude  $(M + m)g/m$ .
  - (D) moves downward with a constant velocity.
  - (E) has a downward acceleration of magnitude less than  $g$ .
- A8.** Which one of the following statements is true concerning an object executing simple harmonic motion?
- (A) Its velocity is never zero.
  - (B) Its acceleration is never zero.
  - (C) Its velocity and acceleration are simultaneously zero.
  - (D) Its velocity is zero when its acceleration is a maximum.
  - (E) Its maximum acceleration is equal to its maximum velocity.
- A9.** Which one of the following statements is correct concerning the absolute pressure acting on an object in a pool of water at a depth  $h$  below the surface of the water?
- (A) The absolute pressure is directly proportional to  $h$ .
  - (B) The absolute pressure is inversely proportional to  $h$ .
  - (C) The absolute pressure varies linearly with  $h$ .
  - (D) The absolute pressure is independent of  $h$ .
  - (E) The absolute pressure is independent of the value of  $g$ .

- A10.** A wave is described by the equation

$$y = 8 \sin \left[ 2\pi \left( \frac{t}{2} - \frac{x}{20} \right) \right]$$

where all distances are measured in centimetres and the time is measured in seconds. One can conclude that

- (A) the amplitude is 4 cm.
- (B) the wavelength is  $10/\pi$  cm.
- (C) the period is 2 s.
- (D) the frequency is 2 Hz.
- (E) the wave is travelling to the left (in the negative  $x$  direction).

**A11.** A rope of length  $L$  is clamped at both ends. Which one of the following is **not** a possible wavelength for standing waves on this rope?

- (A)  $L/2$             (B)  $2L/3$             (C)  $L$             (D)  $2L$             (E)  $4L$

**A12.** Two uncharged, conducting spheres, A and B, are held at rest on insulating stands and are in contact. A positively charged rod is brought near sphere A (from the side opposite sphere B) but does not touch it. While the rod is in place the two spheres are separated, and then the rod is removed. How will the spheres be charged, if at all?

	Sphere A	Sphere B
(A)	positive	positive
(B)	positive	negative
(C)	negative	positive
(D)	negative	negative
(E)	zero	zero

**A13.** Which of the following statements concerning two identical wave sources which vibrate exactly in phase is **not** correct?

- (A) A difference in path lengths which is zero or an integer number of wavelengths leads to constructive interference.  
 (B) At a constructive interference site, a listener will hear a loud sound.  
 (C) A difference in path lengths which is a half integer number of wavelengths leads to constructive interference.  
 (D) At a destructive interference site, the two waves cancel each other.  
 (E) The resultant disturbance at a point where there are two waves present is the sum of the individual disturbances from the two waves.

**A14.** Which statement, concerning the force exerted between two point charges, both with a positive charge, is **not** correct?

- (A) The force is repulsive.  
 (B) The magnitude of the force is inversely proportional to the square of the distance between the objects.  
 (C) The direction of the force is along the line between the two points.  
 (D) The force is proportional to the magnitude of each of the charges.  
 (E) The force is proportional to the sum of the two charges.

**A15.** A point in space is a distance  $r$  from a point charge  $q_1$  Coulombs and a distance  $2r$  from point charge  $q_2$  Coulombs. What is the correct expression for the potential  $V$  at this point if  $q_1 = q_2$ ?

- (A)  $V = \frac{2kq_1}{r}$     (B)  $V = \frac{5kq_1}{2r}$     (C)  $V = \frac{kq_1}{r}$     (D)  $V = \frac{3kq_1}{2r}$     (E)  $V = \frac{3kq_1}{r}$

**A16.** Which one of the following induced nuclear reactions is **not** possible?

- (A)  ${}^4_2\text{He} + {}^{14}_7\text{N} \rightarrow {}^{17}_8\text{O} + {}^1_1\text{H}$             (B)  ${}^1_1\text{H} + {}^{13}_6\text{C} \rightarrow {}^{14}_7\text{N} + \gamma$   
 (C)  ${}^1_0\text{n} + {}^{10}_5\text{B} \rightarrow {}^7_3\text{Li} + {}^4_2\text{He}$             (D)  ${}^4_2\text{He} + {}^{27}_{13}\text{Al} \rightarrow {}^{30}_{15}\text{P} + {}^1_0\text{n}$   
 (E)  ${}^4_2\text{He} + {}^{13}_7\text{N} \rightarrow {}^{16}_9\text{F} + {}^1_1\text{H}$

**A17.** Which one of the following statements is **not** correct?

- (A) The strong nuclear force has a very short range of approximately  $2 \times 10^{-15}$  m.
- (B) The strong nuclear force is exerted by both protons and neutrons.
- (C) Low  $Z$  stable nuclei usually have the same number of protons as neutrons.
- (D) High  $Z$  stable nuclei have more protons than neutrons.
- (E) The strong nuclear force is an attractive force.

**A18.** Which of the following statements about the human eye is **not** correct?

- (A) The focal length of the eye is variable.
- (B) The lens does not provide all of the contribution to the refraction of light.
- (C) The image produced on the retina is real, inverted and smaller than the object.
- (D) The eye is most relaxed when viewing objects that are close.
- (E) Myopia (nearsightedness) may be corrected by using a diverging lens.

**A19.** Which of the following sequences correctly places three sections of the electromagnetic spectrum in order of short to long wavelengths?

- (A) Visible light, infrared radiation, X-rays
- (B) Infrared radiation, visible light, X-rays
- (C) X-rays, visible light, infrared radiation
- (D) X-rays, infrared radiation, visible light
- (E) Infrared radiation, X-rays, visible light

**A20.** Which one of the following statements concerning the photoelectric effect is **not** correct?

- (A) The maximum kinetic energy of the ejected electrons increases with an increase in intensity of the light source.
- (B) The greater the intensity of the light source, the greater the number of electrons ejected from the surface.
- (C) The amount of energy required to remove an electron from the surface depends on the work function of the material.
- (D) The work required to remove an electron from the surface depends on how strongly the electron is held by the material.
- (E) In order for an electron to be ejected, the incident photon must have a frequency equal to or greater than a minimum frequency.

- B1.** Monochromatic red light ( $\lambda = 664 \text{ nm}$ ) shines through two vertical slits that are  $1.25 \times 10^{-4} \text{ m}$  apart onto a screen. Calculate the angle  $\theta$  between the central bright fringe and the second order bright fringe.

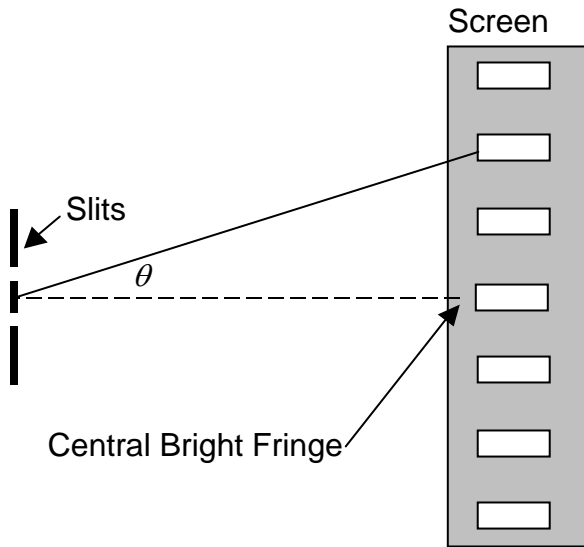

- B2.** A rescue helicopter is lifting a man from a sinking ship by means of a cable and harness. Calculate the tension in the cable given that the man has a weight of  $822 \text{ N}$  and an upward acceleration of  $1.10 \text{ m/s}^2$ .
- B3.** A horizontal, uniform rod is attached to a wall by means of a cable and a frictionless hinge. The rod has a weight of  $145 \text{ N}$  and is at rest. Calculate the tension in the cable.

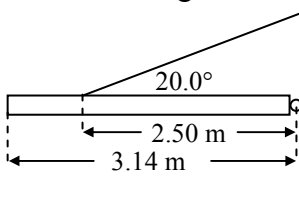

- B4.** An object is oscillating in simple harmonic motion of amplitude  $0.107 \text{ m}$  with a period of  $0.458 \text{ s}$ . If the object was at maximum displacement at time  $t = 0$ , calculate the speed of the object at time  $t = 0.316 \text{ s}$ .
- B5.** A person is talking in a small room; and the sound intensity level is  $61.5 \text{ dB}$  everywhere within the room. If there are eight people talking simultaneously in the room, what is the sound intensity level?

- B6.** A battery with an emf of 16.0 volts and with negligible internal resistance is connected across two resistors in parallel, with resistances of  $148\ \Omega$  and  $744\ \Omega$  respectively. Calculate the current flowing through the  $148\ \Omega$  resistor.

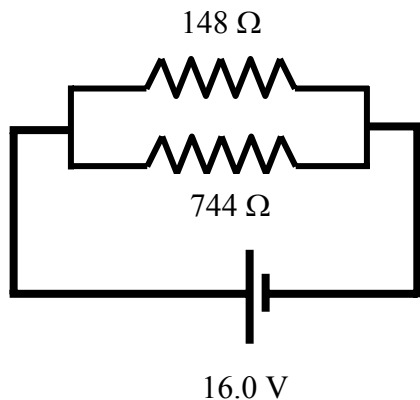

- B7.** A specific frequency of light has a wavelength of  $6.00 \times 10^{-7}\ \text{m}$  in water. Given that water has an index of refraction of 1.33, calculate the frequency of the light.
- B8.** A car of mass 1210 kg has a speed of 27.8 m/s as it goes around a flat curve of radius 125 m. Calculate the magnitude of the frictional force between the car and the road surface
- B9.** The body of an iron-age warrior found in a peat bog at Lindow Marsh near Manchester, England was measured to have a Carbon-14 activity of 0.171 Bq/g of carbon. If the activity of Carbon-14 was 0.230 Bq/g at time  $t = 0$  and the decay constant is  $1.21 \times 10^{-4}\ \text{y}^{-1}$ , calculate the age (in years) of the remains of the warrior.
- B10.** Calculate the longest wavelength of electromagnetic radiation that can be used to ionize the ground state of hydrogen.
- C1.** A 70.0-kg circus performer is fired from a cannon that is elevated at an angle of  $40.0^\circ$  above the horizontal. The cannon uses strong elastic bands to propel the performer, much in the same way that a slingshot fires a stone. Setting up for this stunt involves stretching the bands by 3.00 m from their unstrained length. At the point where the performer flies free of the bands, his height  $h$  above the floor is the same as that of the net into which he is shot. He takes 2.14 s to travel the horizontal distance of 26.8 m between this point and the net. Ignore the effects due to friction and air resistance.

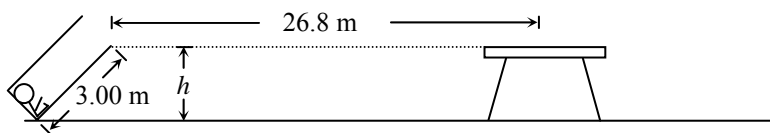

- (a) Calculate the speed of the performer when he flies free of the bands.

- (b) Calculate the effective spring constant of the firing mechanism. If you did not obtain an answer for (a) use 17.0 m/s.

**C2.** A proton is accelerated from rest along the horizontal positive  $x$  axis by a potential difference of 4250 V.

- (a) Calculate the kinetic energy of the proton (in eV) when it has finished accelerating.
- (b) Calculate the speed of the proton immediately after it has finished accelerating.
- (c) The proton now encounters a magnetic field  $\mathbf{B}$  that is directed vertically into the plane of the page. Draw a diagram to clearly indicate in which direction the magnetic force acts at the moment when the proton first encounters the magnetic field.
- (d) If the proton has a speed  $v$ , show that the radius  $r$  of the circular trajectory in the magnetic field  $B$  for the proton is given by  $r = \frac{mv}{eB}$
- (e) If the particle had been an alpha particle with a speed of  $7.15 \times 10^5$  m/s, rather than a proton, calculate the magnitude of the magnetic field that would need to be applied to produce a circular trajectory of 1.28 m. The mass of an alpha particle is  $6.63 \times 10^{-27}$  kg.

**C3.** X-ray photons with a wavelength of 0.312 nm collide with electrons in a graphite target and are scattered through an angle of  $145^\circ$  with respect to their original direction.

- (a) Calculate the energy (in eV) of a single incoming X-ray photon.
- (b) Calculate the momentum of the scattered X-ray photon.
- (c) Calculate the frequency of the scattered X-ray photon.
- (d) Calculate the energy transferred to the recoiling electron.