

# UNIVERSITY OF SASKATCHEWAN

Department of Physics and Engineering Physics

## Physics 115.3

### FINAL EXAMINATION

December 19, 2019

Time: 3 hours

NAME: \_\_\_\_\_  
(Last)                      **Please Print**                      (Given)

STUDENT NO.: \_\_\_\_\_

LECTURE SECTION (please check):

- |                             |                 |                              |                 |
|-----------------------------|-----------------|------------------------------|-----------------|
| <input type="checkbox"/> 01 | Dr. M. Retzlaff | <input type="checkbox"/> 97  | Dr. A. Farahani |
| <input type="checkbox"/> 02 | A. Qamir        | <input type="checkbox"/> C15 | Dr. A. Farahani |
| <input type="checkbox"/> 03 | B. Zulkoskey    |                              |                 |

### INSTRUCTIONS:

1. This is a closed book exam.
2. The test package includes a test paper (this document), an exam booklet, a formula sheet, a scratch card and an OMR (OpScan / bubble) sheet. The test paper consists of 12 pages, including this cover page. **It is the responsibility of the student to check that the test paper is complete.**
3. Only a basic scientific calculator may be used. Graphing or programmable calculators, or calculators with communication capability, or calculator apps in smart phones are **not** allowed.
4. Enter your name and student number on the cover of the test paper and check the appropriate box for your lecture section. Also enter your name on the exam booklet and scratch card.
5. Enter your name and NSID on the OMR (OpScan / bubble) sheet.
6. The test paper, the exam booklet, the formula sheet, the scratch card, and the OMR (OpScan / bubble) sheet must all be submitted.
7. No test materials will be returned.

QUESTION #	MAX. MARKS	MARKS
A1-20	20	
B21-24	8	
B25-28	8	
B29-32	8	
B33-36	8	
B37-40	8	
B41-44	8	
MARK	out of 60:	

**PART A**

**For each of the following questions in Part A, enter the most appropriate response on the OMR (OpScan / bubble) sheet. Use the exam booklet for your rough work.**

- A1. A projectile is launched at some angle (less than  $90^\circ$ ) to the horizontal with initial speed  $v_0$ . Assume air resistance to be negligible. When the projectile reaches its maximum height, which one of the following statement is true?
- (A) The projectile's velocity is zero, but its acceleration is non-zero.
  - (B) The projectile's acceleration is zero, but its velocity is non-zero.
  - (C) Both the velocity and acceleration of the projectile are zero.
  - (D) The velocity and acceleration of the projectile are parallel to each other.
  - (E) The velocity and acceleration of the projectile are perpendicular to each other.
- A2. Quantities  $A$  and  $B$  have same dimension, while quantity  $C$  has different dimension. Which one of the following expressions is **not** meaningful?
- (A)  $AC + BC$                       (B)  $AB + B^2$                       (C)  $\frac{A - B}{C}$
- (D)  $\frac{A - C}{B}$                               (E)  $\frac{A^2 + B^2}{C}$
- A3. A racing car starts from rest, undergoes constant acceleration, and reaches a speed  $v$  after a time  $t_1$ . The car then moves with constant velocity for a time  $t_2$ .  $t_1 = t_2$ . Which one of the following statements is correct for the average velocity of the car during the time  $t_1 + t_2$ ?
- (A)  $\frac{1}{4} v$                       (B)  $\frac{1}{3} v$                       (C)  $\frac{1}{2} v$                       (D)  $\frac{2}{3} v$                       (E)  $\frac{3}{4} v$
- A4. A blue ball is thrown horizontally from the roof of a building and at exactly the same time and height a green ball is dropped from rest. You may assume that the ground is level and that air resistance effects are negligible. Which ball reaches the ground first, and what can be said about their speeds on impact?
- (A) The blue ball reaches the ground first and it is moving faster than the green ball throughout its motion.
  - (B) The green ball reaches the ground first and it is moving faster than the blue ball throughout its motion.
  - (C) Both balls reach the ground at the same time, and with the same speed.
  - (D) Both balls reach the ground at the same time, and the blue ball is moving faster on impact.
  - (E) The answer depends on the masses of the balls.

A5. A box whose weight has a magnitude of  $W$  is sitting on a horizontal surface. The tension in a vertical rope attached to the top of the box has a magnitude  $T$ . If  $T < W$ , the magnitude of the normal force on the box is:

- (A) 0                      (B)  $W + T$                       (C)  $W - T$                       (D)  $T$                       (E)  $W$

A6. An object of mass  $m$  is at rest on a flat horizontal surface. The coefficient of static friction between the object and the surface is  $\mu$ . A horizontal force of magnitude  $F$  is applied to the object, but the object does not move. What is the magnitude of the static frictional force on the object?

- (A)  $\mu mg$                       (B)  $mg$                       (C)  $\mu F$                       (D)  $F$                       (E) 0

A7. Two objects, A and B, are connected by a string as shown in the diagram below. The mass of B is greater than the mass of A. The surface and pulley are frictionless, and the string and pulley have negligible masses. The magnitude of the acceleration of B is  $a_B$ , the magnitude of the acceleration of A is  $a_A$  and  $g$  is the magnitude of the acceleration due to gravity. Which one of the following statements is correct?

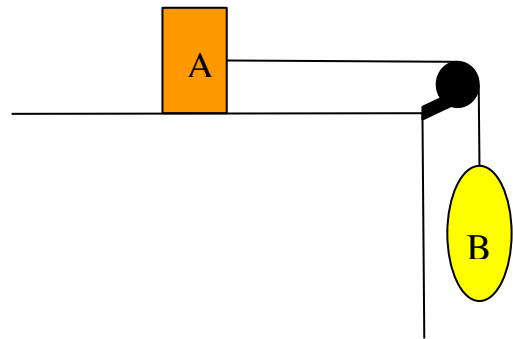

- (A)  $a_B > g$                       (B)  $a_B = g$   
(C)  $a_B < g$                       (D)  $a_B > a_A$   
(E)  $a_B < a_A$

A8. A block of mass  $m$  is dropped from a height  $h_1$  onto a spring, and as the block comes to rest, the spring is compressed a distance  $d$ . The block is then dropped from a second height  $h_2$  and the spring is compressed a distance  $3d$ . Assuming that there are negligible energy losses, what is the relationship between  $h_1$  and  $h_2$ ?

- (A)  $h_2 = h_1$                       (B)  $h_2 = 3h_1$                       (C)  $h_2 = \frac{9}{2}h_1$                       (D)  $h_2 = 9h_1$                       (E)  $h_2 = \sqrt{3}h_1$

A9. Consider an **elastic**, head-on collision between two objects of equal mass. Before the collision, Object 1 was moving to the right with speed  $v$  and Object 2 was at rest on a horizontal frictionless surface. Which one of the following statements concerning the velocities after the collision is correct?

- (A) Object 1 now moves to the left with speed  $v$  and Object 2 remains at rest.  
(B) Object 1 is now at rest and Object 2 moves to the right with speed  $v$ .  
(C) Both objects are now at rest.  
(D) Both objects move to the right with speed  $v$ .  
(E) Both objects move to the right with speed  $\frac{1}{2}v$ .

- A10. A car of mass  $m$  travelling at speed  $v$  crashes into the rear of a truck of mass  $2m$  that is at rest at an intersection. You may assume that the net external force is zero during the collision (the road is horizontal and very icy). If the collision is perfectly inelastic, what is the speed of the car after the collision?
- (A)  $v$                       (B)  $\frac{1}{2}v$                       (C)  $\frac{1}{3}v$                       (D)  $2v$                       (E) zero
- A11. The mass of Mars is one-tenth that of the Earth, and its radius is half the radius of the Earth. Based on this, what would be the acceleration due to gravity on the surface of Mars compared to the acceleration due to gravity on the surface of the Earth?
- (A)  $g_M/g_E = 2/10$                       (B)  $g_M/g_E = 10/2$                       (C)  $g_M/g_E = 4/10$   
(D)  $g_M/g_E = 10/4$                       (E)  $g_M/g_E = 1/20$
- A12. A constant counterclockwise torque is applied to a disk that is initially at rest. Which one of the following statements is correct?
- (A) The centripetal acceleration at the rim is constant and the angular velocity is increasing.  
(B) The angular acceleration is constant and the centripetal acceleration at the rim is constant.  
(C) The centripetal acceleration at the rim is constant and the angular velocity is constant.  
(D) The angular acceleration is constant, and the angular velocity is increasing.  
(E) The angular acceleration is increasing, and the angular velocity is increasing.
- A13. A uniform spherical shell of mass  $M$  and radius  $R$  and a uniform rod of length  $l = 2R$  and mass  $M$  are rotating with the same constant angular speed. The axis of rotation of the sphere passes through its centre and the axis of rotation of the rod also passes through its centre and is perpendicular to the length of the rod. Which one of the following is the correct relationship between the angular momentum of the rod  $L_r$  and the angular momentum of the sphere  $L_s$ ?
- (A)  $L_r = L_s$                       (B)  $L_r = 2L_s$                       (C)  $L_r = \frac{1}{2}L_s$                       (D)  $L_r = \frac{1}{4}L_s$                       (E)  $L_r = \frac{1}{3}L_s$
- A14. Two charged objects  $A$  and  $B$  have charges  $q_A = +3q$  and  $q_B = -2q$  respectively. An amount of charge equal to  $-2q$  is transferred from  $B$  to  $A$ . What are the final charges of the two objects?
- (A)  $q_A = +q$  and  $q_B = -4q$                       (B)  $q_A = +q$  and  $q_B = -2q$   
(C)  $q_A = +5q$  and  $q_B = 0$                       (D)  $q_A = +q$  and  $q_B = 0$   
(E)  $q_A = +5q$  and  $q_B = -4q$
- A15. An electron is accelerated from rest through a potential difference of 20 V. After passing through the potential difference, the kinetic energy of the electron is...
- (A) 20 eV.    (B) 20 J.    (C)  $3.2 \times 10^{-18}$  eV.    (D)  $1.6 \times 10^{-19}$  eV.    (E) 10 J.

- A16. What happens when two charges are placed close to, but not touching, each other?
- (A) They do not exert electrostatic forces on each other.
  - (B) They repel each other.
  - (C) They attract each other.
  - (D) They spontaneously discharge.
  - (E) They either repel or attract each other, depending on the signs of their charges.
- A17. An electron is released from rest in a region where the electric field is uniform and directed to the right. Which one of the following statements is correct?
- (A) The electron will accelerate to the right, moving in the direction in which the electric potential is increasing.
  - (B) The electron will accelerate to the right, moving in the direction in which the electric potential is decreasing.
  - (C) The electron will accelerate to the left, moving in the direction in which the electric potential is increasing.
  - (D) The electron will accelerate to the left, moving in the direction in which the electric potential is decreasing.
  - (E) The electron will remain motionless because if the electric field is uniform there is no net electric force on the electron.
- A18. A light bulb of resistance  $R$  is connected to an ideal battery of emf  $E$ . The power dissipated by the light bulb is  $P$ . If the battery is replaced by one with an emf of  $2E$ , the power dissipated by the same light bulb is:
- (A)  $\frac{1}{4}P$             (B)  $\frac{1}{2}P$             (C)  $P$             (D)  $2P$             (E)  $4P$
- A19. A circuit contains a battery, and three light bulbs of equal resistance connected in parallel. If two of the bulbs burn out, what happens to the power dissipated by the third bulb?
- (A) It becomes zero.
  - (B) It decreases, but is non-zero.
  - (C) It does not change.
  - (D) It becomes twice as large.
  - (E) It becomes three times larger.
- A20. Which statement best explains why a constant magnetic field does no work on a moving charged particle?
- (A) The magnetic field is conservative.
  - (B) The magnetic force is a velocity-dependent force.
  - (C) The magnetic field is a vector and work is a scalar quantity.
  - (D) The magnetic force is always perpendicular to the velocity of the particle.
  - (E) The electric field associated with the particle cancels the effect of the magnetic field on the particle.

**PART B**

**Work out the answers to the following Part B questions.**

**Before scratching any options, be sure to double-check your logic and calculations.**

**You may find it advantageous to do as many of the parts of a question as you can before scratching any options.**

**When you have an answer that is one of the options and are confident that your method is correct, scratch that option on the scratch card. If you reveal a star on the scratch card then your answer is correct (full marks, 2/2).**

**If you do not reveal a star with your first scratch, try to find the error in your solution. If you reveal a star with your second scratch, you receive 1.2 marks out of 2.**

**Revealing the star with your third, fourth, or fifth scratches does not earn you any marks, but it does give you the correct answer.**

**You may answer all six Part B question groupings (B21-24, B25-28, B29-32, B33-36, B37-40, and B41-44) and you will receive the marks for your best 5 groupings.**

**Use the provided exam booklet for your rough work.**

**Grouping B21 to B24:**

Cyclist A is stopped by the side of the road. She starts to accelerate from rest at the instant that she is passed by cyclist B, who is moving at a constant velocity of  $v_B$ . Cyclist A maintains a constant acceleration,  $a_A$ , and eventually overtakes cyclist B.

B21. At the instant that cyclist A overtakes cyclist B, how is her speed,  $v_A$ , related to the speed of cyclist B?

- (A)  $v_A = v_B$     (B)  $v_A = 2v_B$     (C)  $v_A = 4v_B$     (D) need to know  $v_B$     (E) need to know  $a_A$

B22. Given that the following graph correctly shows the velocities of the cyclists as functions of time, how does the time  $t_{AB}$ , when cyclist A overtakes cyclist B, relate to the time  $t_1$  indicated on the graph?

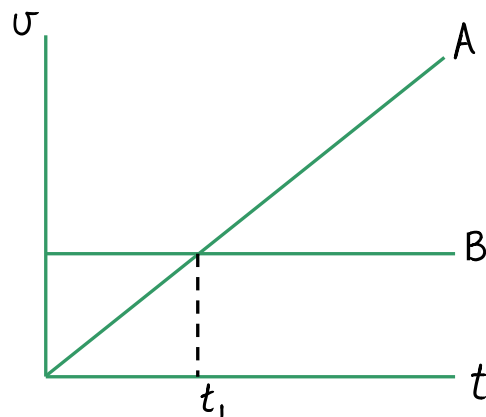

- (A)  $t_{AB} < \frac{1}{2} t_1$     (B)  $t_{AB} > 2t_1$     (C)  $t_{AB} = t_1$     (D)  $t_{AB} = \frac{1}{2} t_1$     (E)  $t_{AB} = 2t_1$

B23. The constant velocity of cyclist B is 7.00 m/s and the constant acceleration of cyclist A is 0.500 m/s<sup>2</sup>. Calculate the time required for cyclist A to overtake cyclist B.

- (A) 14.0 s    (B) 3.50 s    (C) 56.0 s    (D) 28.0 s    (E) 35.0 s

B24. How far has cyclist A ridden when she overtakes cyclist B?

- (A) 7.00 m    (B) 392 m    (C) 196 m    (D) 14.0 m    (E) 28.0 m

**Grouping B25 to B28:**

A bucket of mass  $m_1 = 0.515$  kg and a box of mass  $m_2 = 2.00$  kg are connected by a massless string as shown. The string connecting the objects passes over a massless frictionless pulley. The box is on an inclined surface of angle  $\theta = 40.0^\circ$ . The coefficient of kinetic friction between the box and the incline is 0.300. A student adds sand to the bucket until the objects start to move with a constant speed.

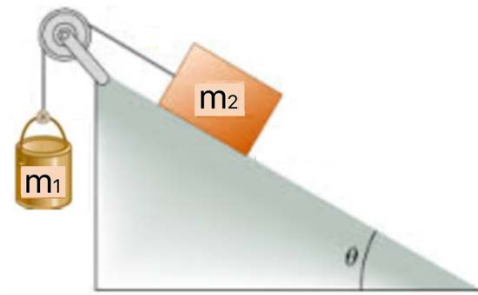

B25. Which one of the following diagrams best represents the free-body diagram for the box?

- (A)
- (B)
- (C)
- (D)
- (E)

B26. What is the tension in the string when the system is moving with a constant speed?

- (A) 11.2 N      (B) 8.09 N      (C) 4.28 N      (D) 19.6 N      (E) 17.1 N

B27. How much sand was added to the bucket when the system is moving with a constant speed?

- (A) 0.643 kg      (B) 1.14 kg      (C) 1.23 kg      (D) 1.50 kg      (E) 1.75 kg

B28. More sand is gradually added to the bucket until the total mass of the bucket + sand reaches 2.50 kg. What is the magnitude of the acceleration of the system?

- (A)  $1.08 \text{ m/s}^2$       (B)  $1.27 \text{ m/s}^2$       (C)  $1.23 \text{ m/s}^2$       (D)  $1.55 \text{ m/s}^2$       (E)  $1.64 \text{ m/s}^2$



**Grouping B29 to B32:**

The figure below shows a block with mass  $m_1 = 4.30$  kg, which is released from rest at point A on a track with negligible friction, at a height of 4.00 m above the level part of the track. A block with mass  $m_2 = 15.5$  kg sits at point B, on the level part of the track, also initially at rest. Block  $m_1$  slides down the track and collides head-on with block  $m_2$ . Block  $m_1$  rises to a height of 0.740 m after the collision.

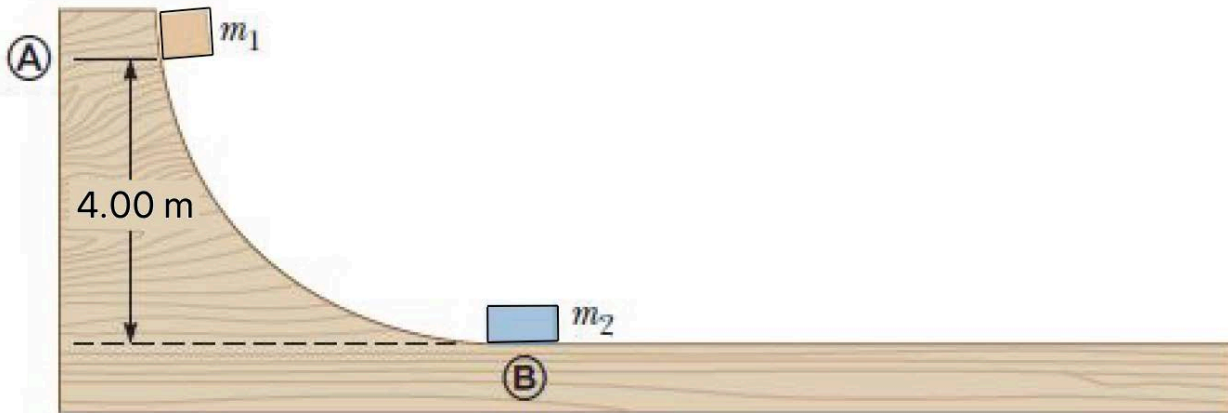

B29. Calculate the speed of block  $m_1$  at the bottom of the ramp.

- (A) 2.69 m/s      (B) 3.81 m/s      (C) 8.85 m/s      (D) 6.26 m/s      (E) 6.17 m/s

B30. Calculate the speed of block  $m_1$  immediately after the collision.

- (A) 1.70 m/s      (B) 2.69 m/s      (C) 3.81 m/s      (D) 2.14 m/s      (E) 1.95 m/s

B31. Calculate the speed of block  $m_2$  immediately after the collision.

- (A) 4.21 m/s      (B) 3.51 m/s      (C) 0.836 m/s      (D) 1.39 m/s      (E) 5.84 m/s

B32. Calculate the mechanical energy lost during the collision.

- (A) 233 J      (B) 0 J      (C) 39.4 J      (D) 128 J      (E) 41.7 J

**Grouping B33 to B36:**

A uniform rod of mass  $M$  and length  $L$  is on a horizontal, frictionless surface. The rod is free to rotate around a vertical axis at its left end, as shown in the top view diagram. The rod is initially at rest. A horizontal force of constant magnitude is then applied to the rod. As the rod starts to rotate, the angle between the applied force and the rod remains the same.

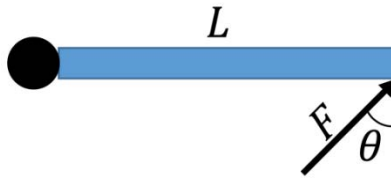

TOP VIEW

B33. Which one of the following is the correct expression for the torque on the rod due to the applied force?

- (A)  $FL \sin \theta$                       (B)  $FL \cos \theta$                       (C)  $\frac{1}{2} FL \sin \theta$   
(D)  $\frac{1}{2} FL \cos \theta$                       (E) 0

B34. Which one of the following is the correct expression for the angular acceleration of the rod?

- (A)  $\frac{12F \sin \theta}{ML}$                       (B)  $\frac{12F \cos \theta}{ML}$                       (C)  $\frac{3F \sin \theta}{ML}$   
(D)  $\frac{3F \cos \theta}{ML}$                       (E)  $\frac{3F \cos \theta}{2ML}$

B35. If  $F = 20.0$  N,  $\theta = 32.0^\circ$ ,  $L = 4.00$  m, and the mass of the rod,  $M = 10.0$  kg, what is the magnitude of the tangential acceleration of a point located at the free end of the rod?

- (A)  $5.25$  m/s<sup>2</sup>    (B)  $4.73$  m/s<sup>2</sup>    (C)  $5.47$  m/s<sup>2</sup>    (D)  $4.81$  m/s<sup>2</sup>    (E)  $5.09$  m/s<sup>2</sup>

B36. If  $F = 20.0$  N,  $\theta = 32.0^\circ$ ,  $L = 4.00$  m, and the mass of the rod,  $M = 10.0$  kg, what is the net work done on the rod during the first 5.00 seconds of its motion?

- (A) +955 J                      (B) +1080 J                      (C) -1030 J  
(D) -1080 J                      (E) +1030 J

**Grouping B37 to B40:**

B37. Which one of the following statements is correct regarding the electric field created by a negative point charge?

- (A) The electric field points toward the charge and its magnitude is inversely proportional to the square of the distance from the charge.
- (B) The electric field points away from the charge and its magnitude is inversely proportional to the square of the distance from the charge.
- (C) The electric field points toward the charge and its magnitude is inversely proportional to the distance from the charge.
- (D) The electric field points away from the charge and its magnitude is inversely proportional to the distance from the charge.
- (E) The electric field points away from the charge and its magnitude is directly proportional to the distance from the charge.

Three charges,  $q_1 = q = +2.00$  nC,  $q_2 = -2q = -4.00$  nC, and  $q_3 = q = +2.00$  nC, are arranged as in the diagram. The distances are  $x = 6.00$  cm and  $y = 3.00$  cm.

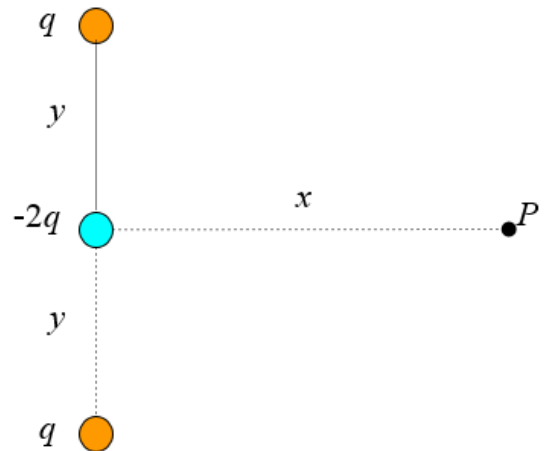

B38. Which direction, as indicated in the diagram at the right, best represents the direction of the net electric field at point  $P$ ?

- (A) 1      (B) 2      (C) 3      (D) 4      (E) 5

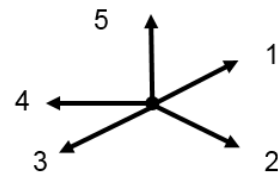

B39. Calculate the magnitude of the electric field at  $P$ .

- (A) 85.1 N/C      (B)  $3.00 \times 10^2$  N/C      (C)  $2.84 \times 10^3$  N/C  
(D)  $4.99 \times 10^3$  N/C      (E)  $2.00 \times 10^3$  N/C

B40. Calculate the electric potential at  $P$ .

- (A)  $-63.3$  V      (B)  $-127$  V      (C)  $+1.14 \times 10^3$  V      (D)  $+599$  V      (E)  $-31.6$  V

**Grouping B41 to B44:**

Consider the following circuit:

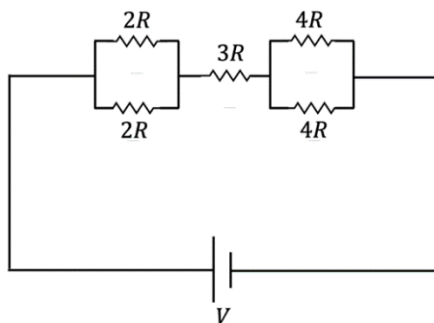

B41. If the voltage of the battery is 25.0 V and the total current drawn from the battery is 2.00 A, calculate the equivalent resistance of the circuit.

- (A) 12.8  $\Omega$       (B) 12.2  $\Omega$       (C) 13.1  $\Omega$       (D) 12.1  $\Omega$       (E) 12.5  $\Omega$

B42. Calculate the value of  $R$ .

- (A) 2.46  $\Omega$       (B) 2.57  $\Omega$       (C) 2.73  $\Omega$       (D) 2.08  $\Omega$       (E) 2.38  $\Omega$

B43. How much energy is dissipated in the  $3R$  resistor in a time of 1.00 minute?

- (A) 1.50 kJ      (B) 1.96 kJ      (C) 2.25 kJ      (D) 1.75 kJ      (E) 2.12 kJ

B44. Calculate the current through each of the  $2R$  resistors.

- (A) 3.00 A      (B) 1.00 A      (C) 2.00 A      (D) 1.44 A      (E) 1.54 A

***END OF EXAMINATION***