

PART A

FOR EACH OF THE FOLLOWING QUESTIONS IN PART A, ENTER THE MOST APPROPRIATE RESPONSE ON THE OMR SHEET.

- A1. If the radius of a circle is decreased by 8.0% the area of the circle decreases by
(A) 4.0% (B) 8.0% (C) 12% (D) 15% (E) 64%
- A2. The speed of sound in a gas is given by $v = \sqrt{\frac{\gamma k_B T}{m}}$, where v is speed in m/s, γ is a dimensionless constant, T is temperature in kelvins (K) and m is mass in kg. What are the units for the Boltzmann constant, k_B ?
(A) $\text{kg}\cdot\text{m}^2\cdot\text{s}^2\cdot\text{K}$ (B) $\text{kg}\cdot\text{m}^2\cdot\text{s}^{-2}\cdot\text{K}^{-1}$ (C) $\text{kg}^{-1}\cdot\text{m}^{-2}\cdot\text{s}^2\cdot\text{K}$
(D) $\text{kg}\cdot\text{m}/\text{s}$ (E) $\text{kg}\cdot\text{m}^2\cdot\text{s}^{-2}$
- A3. A little boy on a sled is sliding down a hill at the park. Which one of the following statements concerning the friction force between the sled and the snow is **TRUE**?
(A) The friction force acts in the direction of motion.
(B) The friction force is proportional to the normal force exerted on the sled by the snow.
(C) The friction force acts perpendicularly to the direction of motion.
(D) The friction force must be zero.
(E) The friction force is a static friction force.
- A4. Which one of the following statements is **FALSE**?
(A) An object in translational equilibrium may be at rest.
(B) An object in translational equilibrium may be moving at constant velocity.
(C) An object in translational equilibrium may be moving in uniform circular motion.
(D) The net force on an object in translational equilibrium is zero.
(E) An object in translational equilibrium may have zero kinetic energy.
- A5. Consider a rock that is thrown vertically upward. At the instant that the rock reaches its maximum height, the acceleration of the rock is
(A) 0. (B) g downward. (C) g upward.
(D) less than g , downward. (E) dependent on whether or not there is air resistance.
- A6. A figure skater is spinning with arms outstretched, when the strap of her wristwatch breaks. Which one of the following statements best describes the motion of the wristwatch, **as viewed from above**?
(A) It orbits around the skater as if the strap had not broken.
(B) It spirals inward toward the skater.
(C) It moves off in an ever-widening arc.
(D) It orbits around the skater at a fixed radius with decreasing speed.
(E) It moves away from the skater along a straight-line trajectory, tangent to its original circular trajectory.
- A7. Which of the following methods of moving a box from the ground to the back of a truck requires the least amount of total work to be done on the box? Initially the box is at rest on the ground and finally it is at rest in the back of the truck.
(A) Slowly lifting the box vertically.
(B) Slowly sliding the box up a frictionless ramp.
(C) Rapidly lifting the box vertically.
(D) Rapidly sliding the box up a frictionless ramp.
(E) **All** of the above methods involve the **same** amount of total work.
- A8. Geo-stationary satellites orbit at an altitude that ensures that they remain above the same position on the Earth's surface at all times. The period of a satellite in a geo-stationary orbit is
(A) 1.0 hour. (B) 24 hours. (C) 365 days.
(D) 28 days. (E) dependent on the mass of the satellite.

- A9.** An object of mass m moving with a speed v has a perfectly inelastic collision with an object of mass $2m$. The speed of the objects immediately after the collision is...
- (A) $\frac{v}{3}$. (B) $\frac{v}{2}$. (C) v . (D) $2v$. (E) $3v$.
- A10.** A metallic sphere has a net charge of $+4.0$ nC. A negatively-charged rod has a net charge of -6.0 nC. When the rod touches the sphere 8.2×10^9 electrons are transferred to the sphere. What is the new net charge on the sphere?
- (A) -2.0 nC (B) -4.7 nC (C) -2.7 nC (D) $+2.7$ nC (E) $+4.0$ nC
- A11.** The magnitude of the electrostatic force between two charged particles is F . If the distance between the two particles is doubled and the charge on one of the particles is also doubled then the magnitude of the new electrostatic force will be...
- (A) $\frac{F}{4}$. (B) $\frac{F}{2}$. (C) F . (D) $2F$. (E) $4F$.
- A12.** Consider a charge $+Q$. Located directly West of this charge is a charge $-Q$. The net electric field at the point along the line connecting the two charges and midway between them is...
- (A) 0. (B) directed to the West. (C) directed to the East.
(D) directed to the North. (E) directed to the South.
- A13.** Which one of the following statements concerning electric fields is **FALSE**?
- (A) The electric force on a negatively-charged particle is in the opposite direction to the electric field.
(B) The SI unit of electric field can be written as N/C.
(C) Electric field is a scalar quantity.
(D) The SI unit of electric field can be written as V/m.
(E) The electric field is defined as the force per unit charge.
- A14.** The electric field at a distance R from a charged particle has magnitude E . If the distance from the charged particle is increased to $3R/2$, what is the new magnitude of the electric field in terms of E ?
- (A) $\frac{3E}{2}$ (B) $\frac{2E}{3}$ (C) $\frac{9E}{2}$ (D) $\frac{9E}{4}$ (E) $\frac{4E}{9}$
- A15.** A tiny charged object of mass m is at rest in mid-air between two plates. The top plate is negatively-charged and the lower plate is positively-charged. Which one of the following statements is **TRUE**?
- (A) The electric field between the plates points downward.
(B) The object is negatively-charged.
(C) The electric field between the plates is directed parallel to the plates.
(D) The magnitude of the electric force on the object is equal to mg .
(E) The two plates are at the same potential.
- A16.** A piece of conducting wire has a resistance R . Another piece of wire of the same material is twice as long and has twice the diameter. The resistance of the second piece of wire is...
- (A) $\frac{1}{2}R$. (B) $2R$. (C) $4R$. (D) $\frac{1}{4}R$. (E) R .
- A17.** Which one of the following statements concerning electrical potential energy is **FALSE**?
- (A) Electrical potential energy is a scalar quantity.
(B) A positive charge gains electrical potential energy if it moves toward another positive charge.
(C) A negative charge gains electrical potential energy if it moves toward another negative charge.
(D) A negative charge can never have a positive change in electrical potential energy.
(E) Electrical potential energy changes if a charge is accelerated by a potential difference.

- A18.** A positively-charged particle initially moving North enters a region where there is a magnetic field directed vertically down. The initial direction of the magnetic force on the charged particle is...
- (A) East. (B) West. (C) down.
(D) up. (E) South.

- A19.** The magnetic force on a point charge in a magnetic field is greatest when...
- (A) the charge moves in the direction of the magnetic field.
(B) the charge moves perpendicular to the direction of the magnetic field.
(C) the charge moves in the opposite direction of the magnetic field.
(D) the charge is at rest.
(E) the velocity of the charge has components that are both parallel and perpendicular to the magnetic field.

- A20.** The graph shows the variation in radiation intensity per unit wavelength versus wavelength for a perfect blackbody at temperature T . Correctly complete the following statement: As the temperature of the blackbody is increased, the peak in intensity of this curve...

- (A) will remain constant.
(B) will be shifted to longer wavelengths and its magnitude will increase.
(C) will be shifted to shorter wavelengths and its magnitude will increase.
(D) will be shifted to longer wavelengths and its magnitude will decrease.
(E) will be shifted to shorter wavelengths and its magnitude will decrease.



- A21.** If a photoelectric material has a work function ϕ , the threshold wavelength for the material is given by:

- (A) $\frac{\phi}{hc}$ (B) hf (C) $\frac{hc}{\phi}$ (D) $\frac{\phi}{e}$ (E) $\frac{\phi}{hf}$

- A22.** A photon of energy 1.022 MeV produces a positron-electron pair. Which one of the following statements is **FALSE**?

- (A) Momentum is conserved in this process.
(B) Total Energy is conserved in this process.
(C) Another particle must take part in the reaction to conserve momentum.
(D) Mass is conserved in this process.
(E) The photon has zero mass.

- A23.** Electrons are accelerated in an X-ray tube by a potential difference V_1 and strike a metal target. The minimum wavelength of the x-rays produced is λ_1 . The potential difference is doubled. What is the new minimum wavelength, in terms of λ_1 ?

- (A) $\frac{1}{4} \lambda_1$ (B) $\frac{1}{2} \lambda_1$ (C) λ_1 (D) $2\lambda_1$ (E) $4\lambda_1$

- A24.** In the Compton effect, a photon of wavelength λ and frequency f hits an electron that is initially at rest. Which one of the following occurs as a result of the collision?

- (A) The photon is absorbed completely.
(B) The photon gains energy, so the final photon has a frequency greater than f .
(C) The photon gains energy, so the final photon has a wavelength greater than λ .
(D) The photon loses energy, so the final photon has a frequency less than f .
(E) The photon loses energy, so the final photon has a wavelength less than λ .

- A25.** Which one of the following will result in an electron transition from the $n = 7$ level to the $n = 4$ level in a hydrogen atom?

- (A) emission of a 0.28 eV photon (B) emission of a 0.57 eV photon
(C) emission of a 0.85 eV photon (D) absorption of a 0.28 eV photon
(E) absorption of a 0.57 eV photon

PART B

ANSWER FIVE PART B QUESTIONS AND INDICATE YOUR CHOICES ON THE COVER PAGE.

IN EACH OF THE PART B QUESTIONS ON THE FOLLOWING PAGES, GIVE THE COMPLETE SOLUTION AND ENTER THE FINAL ANSWER IN THE BOX PROVIDED. THE ANSWERS MUST CONTAIN THREE SIGNIFICANT FIGURES AND THE UNITS MUST BE GIVEN. SHOW AND EXPLAIN YOUR WORK – NO CREDIT WILL BE GIVEN FOR ANSWERS ONLY. EQUATIONS NOT PROVIDED ON THE FORMULAE SHEET MUST BE DERIVED. USE THE BACK OF THE PREVIOUS PAGE FOR YOUR ROUGH WORK.

- B1.** While deciding where to hang a picture frame, you press it against the wall to prevent it from falling. The frame weighs 5.14 N and you push on it with the minimum force of 6.05 N at an angle of 40.5° from the vertical, in order to just prevent the frame from falling.
- (a) The diagram below shows a side view of the frame and the wall. The pushing force is shown. Draw all the other forces acting on the frame and show your choice of coordinate system. (4 marks)

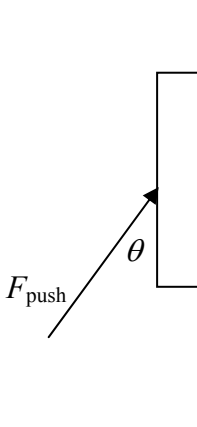

- (b) Calculate the coefficient of static friction between the frame and the wall. (6 marks)

- B2.** (a) A 0.454 kg mass is suspended vertically from an ideal spring. The mass stretches the spring from its relaxed length of 6.67 cm to a total length of 7.95 cm. Calculate the spring constant of the spring. (4 marks)

- (b) The same ideal spring with the same mass attached to it is then placed on a horizontal frictionless surface, and the spring is held fixed at the other end. The mass is pulled horizontally so that the spring stretches to a total length of 8.50 cm. The mass is then released and it oscillates back and forth. Calculate the maximum speed of the mass as it oscillates. (If you did not obtain an answer for (a), use 3.75×10^2 N/m.) (6 marks)

B3. A block of wood of mass 1.64 kg is at rest on a frictionless horizontal surface. A bullet of mass 0.0192 kg is fired at the block of wood. The bullet is moving horizontally with a speed of 325 m/s when it strikes the block of wood. The bullet passes through the block of wood, emerging with a speed of 127 m/s.



(a) Calculate the speed of the block of wood after the bullet has passed through it. (4 marks)

(b) After the bullet has passed through it, the block slides across the horizontal surface and encounters an area where the coefficient of kinetic friction between the block and the area is 0.111. Calculate the distance that the block slides in this area before coming to rest. (If you did not obtain an answer for (a), use a value of 2.75 m/s.) (4 marks)

(c) Calculate the mechanical energy that is dissipated in the bullet-block interaction. (If you did not obtain an answer for (a), use a value of 2.75 m/s.) (2 marks)

B4. The circuit diagram below represents the circuit in an iPod/mp3 player. Resistances R_1 , R_2 and R_3 represent the processor, audio speakers and screen respectively. Resistance r is the internal resistance of the battery. The resistances have the following values: $R_1 = 40.0 \Omega$, $R_2 = 55.0 \Omega$, $R_3 = 61.0 \Omega$ and $r = 1.20 \Omega$. The battery has an emf of 3.70 Volts.

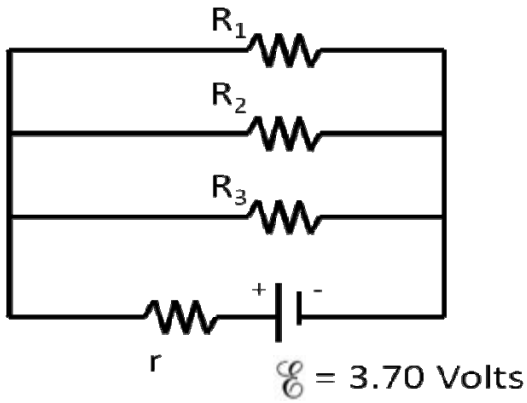

(a) Calculate the current flowing through the internal resistance r . (5 marks)

(b) Calculate the total power dissipated in the circuit. (If you did not obtain an answer for (a), use a value of 0.150 A.) (2 marks)

(c) If the battery has a rating of 1.40 Amp-hours, how long can the player be left on until the battery is completely drained? (3 marks)

- B5.** An alpha particle (charge of $+2e$) with a mass of 6.64×10^{-27} kg is travelling with a speed of 12.3 m/s when it enters a slit in a plate. The alpha particle accelerates toward a second plate that is at a potential of 305 V lower than the first plate. You may ignore any gravitational effects.
- (a) Calculate the speed of the alpha particle after it passes through a slit in the second plate.
(4 marks)

- (b) After passing through the slit in the second plate the alpha particle enters a region where there is a magnetic field of 0.185 T directed perpendicular to the alpha particle's velocity. Calculate the radius of the alpha particle's trajectory while it is in the magnetic field.
(If you did not obtain a value for (a), use 1.50×10^5 m/s.) (6 marks)

B6. Ultraviolet light of wavelength 226 nm illuminates a metal surface in a phototube and electrons are ejected. A stopping potential of 1.15 V is able to *just* prevent any of the ejected electrons from reaching the opposite electrode.

(a) Calculate the work function of the metal surface. (3 marks)

(b) Calculate the maximum speed of the ejected electrons. (4 marks)

(c) Calculate the maximum wavelength of photons that will cause electrons to be ejected from the metal. (If you did not obtain an answer for (a), use 4.50 eV.) (3 marks)

B7. In a scattering experiment, a photon of wavelength 0.0100 nm is incident on a stationary free electron. The scattered photon has a wavelength of 0.0118 nm.

(a) Calculate the scattering angle with respect to the direction of the incident photon. (4 marks)

(b) Calculate the energies of both the incident and scattered photons. (3 marks)

incident:

scattered:

(c) Calculate the kinetic energy of the free electron after the collision. (3 marks)