

**UNIVERSITY OF SASKATCHEWAN**  
**Department of Physics and Engineering Physics**

**Physics 111.6**  
**MIDTERM TEST #2**

November 15, 2001

Time: 90 minutes

NAME: \_\_\_\_\_ STUDENT NO.: \_\_\_\_\_  
(Last)                      **Please Print**                      (Given)

LECTURE SECTION (please circle):

- 01      Dr. R.E. Pywell
- 02      B. Zulkoskey
- 03      Dr. A.H. Manson
- C15     F. Dean

**INSTRUCTIONS:**

1. You should have a test paper, a formula sheet, and an OMR sheet. The test paper consists of 9 pages. **It is the responsibility of the student to check that the test paper is complete.**
2. Enter your name and STUDENT NUMBER on the OMR sheet.
3. The test paper, the formula sheet and the OMR sheet must all be submitted.
4. The test paper will be returned. The formula sheet and the OMR sheet will NOT be returned.

***PLEASE DO NOT WRITE ANYTHING ON THIS TABLE***

QUESTION NUMBER	MAXIMUM MARKS	MARKS OBTAINED
Part A	10	
Part B	10	
C1	5	
C2	5	
C3	5	
TOTAL	35	

continued on page 2 ...

**PART A**

**FOR EACH OF THE FOLLOWING QUESTIONS IN PART A, ENTER THE MOST APPROPRIATE RESPONSE ON THE OMR SHEET.**

- A1.** In gravity-free space a rock, which is attached to the end of a string, is swung in a circular path. If the string breaks the rock travels in a straight line. Which law of motion best explains why the rock travels in a straight line?
- (A) Newton's first law of motion.
  - (B) Newton's second law of motion.
  - (C) Newton's third law of motion.
  - (D) Newton's law of Universal Gravitation.
  - (E) Newton's law of Centripetal Acceleration.
- A2.** A ball is whirled on the end of a string in a horizontal circle of radius  $R$  at a constant speed  $v$ . The centripetal acceleration of the ball can be increased by a factor of 4 by
- (A) keeping the speed fixed and increasing the radius by a factor of 4.
  - (B) keeping the radius fixed and increasing the speed by a factor of 4.
  - (C) keeping the radius fixed and increasing the period by a factor of 4.
  - (D) keeping the radius fixed and decreasing the period by a factor of 4.
  - (E) keeping the speed fixed and decreasing the radius by a factor of 4.
- A3.** The Earth exerts the necessary centripetal force on an orbiting satellite to keep it moving in a circle at a constant speed. Which statement best explains why the speed of the satellite does not change even though there is a net force exerted on it?
- (A) The satellite is in equilibrium.
  - (B) The acceleration of the satellite is  $0 \text{ m/s}^2$ .
  - (C) The centripetal force has magnitude  $mv^2/r$ .
  - (D) The centripetal force is cancelled by the reaction force.
  - (E) The centripetal force is always perpendicular to the velocity.
- A4.** Work requires the action of a force. However, a force will do work on an object only if
- (A) the object does not move while the force is acting on it.
  - (B) no other forces are acting on the object.
  - (C) the force has a component acting along the object's direction of motion.
  - (D) there is no friction present.
  - (E) the object does not accelerate while the force is acting.
- A5.** Block 1 (with mass  $m$ ) slides at constant speed across a frictionless surface and collides head-on with Block 2 (with mass  $2m$ ). Following the collision, the blocks move in opposite directions. Which one of the following statements is correct concerning the magnitude of the impulse experienced by each block during the collision?
- (A) Block 1 experiences the greater magnitude impulse.
  - (B) Block 2 experiences the greater magnitude impulse.
  - (C) Both blocks experience the same magnitude impulse.
  - (D) No statement can be made concerning the relative magnitude of the impulses without knowing the value of  $m$ .
  - (E) No statement can be made concerning the relative magnitude of the impulses without knowing the initial speed of Block 2.

continued on page 3 ...

- A6.** Two balls of equal size are dropped from the same height from the roof of a building. One ball has twice the mass of the other. Ignoring air resistance, when the balls reach the ground, how do their kinetic energies compare?
- (A) The lighter ball has one fourth as much kinetic energy as the other ball.
  - (B) The lighter ball has one half as much kinetic energy as the other ball.
  - (C) The lighter ball has the same kinetic energy as the other ball.
  - (D) The lighter ball has twice as much kinetic energy as the other ball.
  - (E) The lighter ball has four times as much kinetic energy as the other ball.
- A7.** Complete the following statement: Momentum will be conserved in a two-body collision only if
- (A) both bodies come to rest.
  - (B) the collision is perfectly elastic.
  - (C) the collision is perfectly inelastic.
  - (D) the kinetic energy of the system is conserved.
  - (E) the net external force acting on the two-body system is zero.
- A8.** Two points are located in a rigid wheel that is rotating, about a fixed axis through its centre, with a *decreasing* angular velocity. Point A is located on the rim of the wheel and point B is halfway between the centre and the rim. Which one of the following statements is true concerning this situation?
- (A) Both points have the same centripetal acceleration.
  - (B) Both points have the same tangential acceleration.
  - (C) The angular velocity of point A is greater than that of point B.
  - (D) Both points have the same instantaneous angular velocity.
  - (E) Each second, point A turns through a greater angle than point B.
- A9.** A circular hoop rolls without slipping on a flat horizontal surface. It is also accelerating. Which one of the following statements is true?
- (A) All points on the rim of the hoop have the same instantaneous speed, relative to the ground.
  - (B) All points on the rim of the hoop have the same instantaneous velocity, relative to the ground.
  - (C) Every point on the rim of the hoop has a different instantaneous velocity, relative to the ground.
  - (D) All points on the rim of the hoop have acceleration vectors that point at a tangent to the hoop.
  - (E) All points on the rim of the hoop have acceleration vectors that point towards the centre of the hoop.
- A10.** Which one of the following statements concerning the moment of inertia  $I$  of an object is **false**?
- (A)  $I$  may be expressed in units of  $\text{kg m}^2$ .
  - (B)  $I$  depends on the location of the axis of rotation relative to the particles that make up the object.
  - (C)  $I$  depends on the orientation of the axis of rotation relative to the particles that make up the object.
  - (D)  $I$  depends on the angular acceleration of the object as it rotates.
  - (E) Of the particles that make up the object, it is possible that the particle with the smallest mass could contribute the greatest amount to  $I$ .

**PART B**

**FOR EACH OF THE FOLLOWING PROBLEMS, B1 TO B5, ON PAGES 4 TO 6, WORK OUT THE SOLUTION IN THE SPACE PROVIDED AND ENTER YOUR ANSWERS ON PAGE 6.**

**ONLY THE ANSWERS WILL BE MARKED. THE SOLUTIONS WILL NOT BE MARKED.**

- B1.** To prepare astronauts for living on Mars they are placed in a space station that is rotating at  $0.135 \text{ rad/s}$ . What should be the radius  $r$  of the space station for the astronauts to have an apparent weight of exactly one third their weight on Earth?

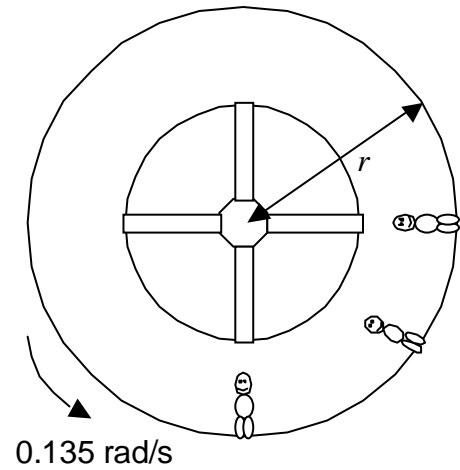

- B2.** A curling stone is initially at rest on a frictionless, horizontal ice surface. Calculate the power expended by a constant, horizontal force of  $167 \text{ N}$ , which moves the stone a distance of  $2.50 \text{ m}$  along the ice in a time of  $0.750 \text{ s}$ .

**B3.** A curling rock, moving along the ice in the  $+x$  direction collides with another, stationary curling rock. Both rocks have the same mass. After the collision we find that rock 1 is moving with speed  $v_1 = 0.855$  m/s at an angle of  $30.0^\circ$  to the  $+x$  direction, and rock 2 is moving at an angle of  $58.0^\circ$  to the  $+x$  direction as shown. Calculate the speed  $v_2$  of rock 2 after the collision. Ignore friction with the ice.

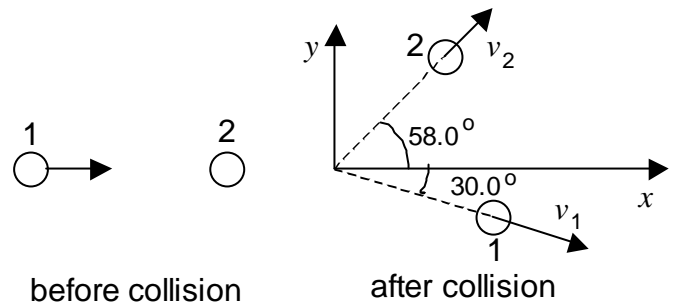

**B4.** A car is rounding a curve of radius 25.0 m. As it does so its speed is increasing at a rate of  $2.00$  m/s<sup>2</sup>. At the instant when its speed is 9.00 m/s, calculate the magnitude of the car's instantaneous total acceleration.

- B5.** A wheel turns through an angle of 188 radians in 8.15 s. Its angular speed at the end of the 8.15 s time interval is 40.0 rad/s. If the angular acceleration is constant in this time interval, calculate the angular speed of the wheel at the beginning of the 8.15 s time interval.

**ANSWERS FOR PART B**

**ENTER THE ANSWERS FOR THE PART B PROBLEMS IN THE BOXES BELOW.**

**THE ANSWERS MUST CONTAIN THREE SIGNIFICANT FIGURES AND THE UNITS MUST BE GIVEN.**

**ONLY THE ANSWERS WILL BE MARKED. THE SOLUTIONS WILL NOT BE MARKED.**

**B1**

**B2**

**B3**

**B4**

**B5**

continued on page 7 ...

**PART C**

**IN EACH OF THE PART C QUESTIONS ON THE FOLLOWING PAGES, GIVE THE COMPLETE SOLUTION AND ENTER THE FINAL ANSWER IN THE BOX PROVIDED.**

**THE ANSWERS MUST CONTAIN THREE SIGNIFICANT FIGURES AND THE UNITS MUST BE GIVEN.**

**SHOW YOUR WORK – NO CREDIT WILL BE GIVEN FOR ANSWERS ONLY. EQUATIONS NOT PROVIDED ON THE FORMULAE SHEET MUST BE DERIVED.**

**USE THE BACK OF THE PREVIOUS PAGE FOR YOUR ROUGH WORK.**

**C1.** A car goes around an un-banked curve with a radius  $r$ . The coefficient of static friction between the car's tires and the road is  $\sigma_s = 0.880$ . The maximum speed that the car can go round this curve without sliding is  $v_{\max}$ . The car then goes around a banked curve, with the same radius  $r$ , at the same speed  $v_{\max}$ . The surface of the banked road is very slippery (frictionless).

- (a) Derive an expression for the speed  $v_{\max}$  on the un-banked curve in terms of  $g$ ,  $\sigma_s$  and  $r$ .

- (b) Calculate the angle of the banking needed if the car is to safely negotiate the frictionless banked curve, at speed  $v_{\max}$ , without sliding.

**C2.** A block of wood of mass 1.50 kg is at rest on a horizontal surface. The coefficient of kinetic friction between the block and the surface is 0.250. A bullet of mass  $2.00 \times 10^{-2}$  kg is now fired at the block. The bullet has a velocity of 280 m/s, directed horizontally, as it enters the block. The bullet becomes embedded in the block.

- (a) Calculate the speed of the block immediately after the bullet-block collision. (Assume that the block moves a negligible distance while the collision is occurring.)

- (b) Calculate the distance that the block (with embedded bullet) slides along the surface after the collision.

**C3.** A uniform plank rests with one end on the horizontal ground, and one end held stationary by a rope, so that

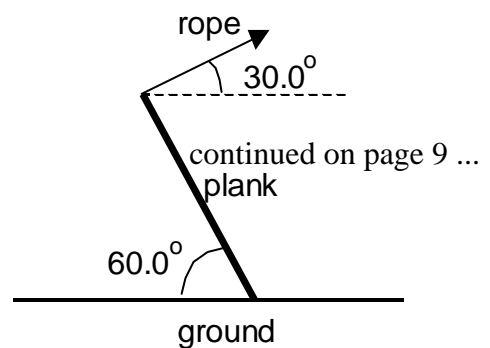



the plank makes an angle of  $60.0^\circ$  with the ground as shown. The rope makes an angle of  $30.0^\circ$  with the horizontal. The mass of the plank is  $20.0 \text{ kg}$ . The plank remains in this position because there is friction between the plank and the ground.

- (a) Calculate the tension in the rope.

- (b) Calculate the magnitude and direction of the static friction force on the end of the plank that is resting on the ground.

***END OF EXAMINATION***