

UNIVERSITY OF SASKATCHEWAN

Department of Physics and Engineering Physics

Physics 115.3

MIDTERM EXAM – Alternative Sitting

October 2019

Time: 90 minutes

NAME: _____ **SOLUTIONS** _____ STUDENT NO.: _____
(Last) **Please Print** (Given)

LECTURE SECTION (please check):

- 01 Dr. M. Ratzlaff
- 02 A. Qamar
- 03 B. Zulkoskey
- 97 Dr. A. Farahani
- C15 Dr. A. Farahani

INSTRUCTIONS:

1. This is a closed book exam.
2. The test package includes a test paper (this document), an exam booklet, a formula sheet, a scratch card and an OMR sheet. The test paper consists of 8 pages, including this cover page. **It is the responsibility of the student to check that the test paper is complete.**
3. Only a basic scientific calculator may be used. Graphing or programmable calculators, or calculators with communication capability, or calculators in smart phones are **not** allowed.
4. Enter your name and student number on the cover of the test paper and check the appropriate box for your lecture section. Also enter your name on the exam booklet and scratch card.
5. Enter your name and NSID on the OMR sheet.
6. The test paper, the exam booklet, the formula sheet, the scratch card, and the OMR sheet must all be submitted.
7. No test materials will be returned.

QUESTION NUMBER	MAXIMUM MARKS	MARKS OBTAINED
A1-12	12	
B1-4	8	
B5-8	8	
B9-12	8	
B13-16	8	
MARK	out of 36:	

PART A

FOR EACH OF THE FOLLOWING QUESTIONS IN PART A, ENTER THE MOST APPROPRIATE RESPONSE ON THE OMR SHEET.

- A1. Forces F_1 and F_2 act on an object, with force F_2 acting in the positive x direction. From the free body diagram and coordinate system shown, which one of the following is the correct expression for the y component of $\vec{F}_1 + \vec{F}_2$?

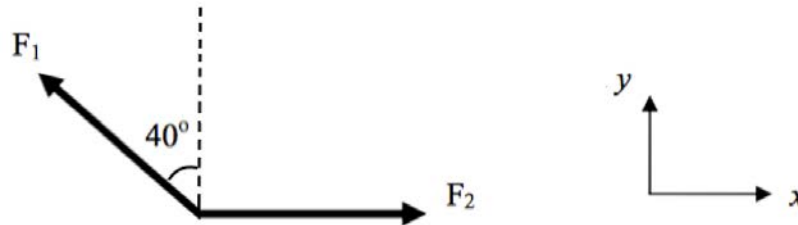

- (A) $F_1 \cos 40^\circ$ (B) $-F_1 + F_2 \cos 40^\circ$ (C) $F_1 \sin 40^\circ + F_2 \cos 40^\circ$
 (D) $-F_1 \sin 40^\circ$ (E) $F_1 \sin 40^\circ$

Since \vec{F}_2 does not have a y -component, the y -component of $\vec{F}_1 + \vec{F}_2$ is the y -component of \vec{F}_1 . Since the angle that is given is with respect to the y -axis, the y -component is $+F_1 \cos(40^\circ)$ (A)

- A2. Which one of the following choices is correct for the units of α in the expression $\alpha = \sqrt{\frac{Fx}{4m}}$, where F is force in Newtons, x is displacement in meters, and m is mass in kilograms
 (A) m/s^2 (B) m/s (C) m^2/s (D) m^2/s^2 (E) $kg\ m/s$

$$[\alpha] = \sqrt{\frac{Nm}{kg}} = \sqrt{\frac{(\cancel{kg} \cdot m / s^2)m}{\cancel{kg}}} = \sqrt{m^2 / s^2} = m / s \quad (B)$$

- A3. Which one of the following values is a reasonable order-of-magnitude estimate of the volume of a medium-sized orange?
 (A) $1\ cm^3$ (B) $10\ cm^3$ (C) $100\ cm^3$ (D) $10\ m^3$ (E) $100\ m^3$

Approximate an orange as a sphere. The volume of a sphere is $\frac{4}{3}\pi r^3 \approx 4r^3 = 4\left(\frac{d}{2}\right)^3 = \frac{4}{8}d^3 = \frac{1}{2}d^3$ where r is radius and d is diameter. A medium-sized orange will easily fit in the palm of your hand, so approximate its diameter as 7 to 8 cm. Therefore the volume is approximately $170\ cm^3$ to $250\ cm^3$. (C)

A4. The position versus time graph of an object moving in one dimension is shown below.

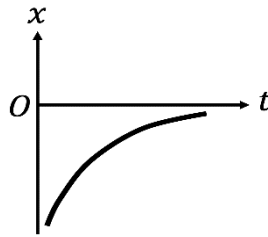

Which one of the following statements about the motion of this object is correct?

- (A) The object is moving with constant velocity in the positive direction.
- (B) The object is moving with constant velocity in the negative direction.
- (C) The object is moving in the positive direction and speeding up.
- (D) The object is moving in the negative direction and slowing down.
- (E) The object is moving in the positive direction and slowing down.

The position of the object is on the negative side of the x -axis, and the object is moving toward the origin. Therefore, the object is moving in the positive direction. The rate of change of position of the object (the slope of the position vs. time graph) is decreasing, so the object is slowing down. (E)

A5. A package is released by a plane flying with a constant horizontal velocity. A truck is directly below the plane at this time. The truck is driving on a flat road in the same direction as the plane is flying. Assume there is no wind or air resistance. Which one of the following statements is correct?

- (A) Whether or not the package lands on the truck depends on the mass of the package.
- (B) If the truck initially has the same velocity as the plane and an acceleration in the same direction as its velocity, the package will land on the truck.
- (C) Whether or not the package lands on the truck depends on the altitude of the plane.
- (D) If the truck has the same constant velocity as the plane, the package will land on the truck.
- (E) If the truck initially has the same velocity as the plane and an acceleration in the opposite direction to its velocity, the package will land on the truck.

With no wind or air resistance, the package will continue to move with the same constant horizontal velocity as the plane, but will also have a vertical component of motion due to its weight. Therefore, if the truck has the same constant velocity as the plane, the package will land on the truck. (D)

- A6. A moving walkway at an airport has a speed v and a length L . A woman stands on the walkway as it moves from one end to the other, while a man in a hurry to reach his flight walks on the walkway with a speed of $2v$ relative to the moving walkway. Compared to the woman's time, how much sooner does the man reach the end of the walkway?

- (A) $\frac{L}{v}$ (B) $\frac{L}{3v}$ (C) $\frac{2L}{3v}$ (D) $\frac{4L}{3v}$ (E) $\frac{L}{2v}$

From $\Delta x = vt$, the woman, standing with the walkway, will move the distance L in a time of $\frac{L}{v}$. The man, moving with a speed of $2v$ relative to the walkway, is moving at a speed of $3v$ relative to the building. Therefore, the man will move the distance L in a time of $\frac{L}{3v}$. The difference in these times, which is how much sooner than the woman that the man reaches the end of the walkway, is $\frac{L}{v} - \frac{L}{3v} = \frac{3L - L}{3v} = \frac{2L}{3v}$ (C)

- A7. If an object is in equilibrium, which one of the following statements is FALSE?

- (A) The object must be at rest.
 (B) The acceleration of the object is zero.
 (C) The net force acting on the object is zero.
 (D) The speed of the object is constant.
 (E) The velocity of the object is constant.

For an object in equilibrium, the net force acting on it, and therefore its acceleration, are zero. This means that the object is either at rest and remaining at rest, **or** is moving at constant velocity. The statement that the object **must** be at rest is false. (A)

- A8. Three blocks are suspended from the ceiling by strings as shown. The top block has mass M , the middle block has mass $2M$, and the bottom block has mass $3M$. The tension in the string between the top block and the ceiling is T . What is the tension, T_1 , in the string connecting the bottom block and middle block?

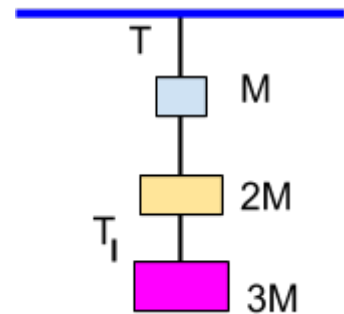

- (A) $3T$ (B) $\frac{3}{5}T$ (C) $\frac{1}{2}T$
 (D) $\frac{2}{3}T$ (E) $6T$

The external forces acting on the system of three blocks are T and the total weight of the three blocks. Since the three blocks are in equilibrium, the tension T must be equal in magnitude to $M_{\text{tot}}g = (M + 2M + 3M)g = 6Mg$. Since the bottom block is in equilibrium, the net force on it must be zero. Therefore, $+T_1 - 3Mg = 0$, so $T_1 = 3Mg = \frac{1}{2}T$. (C)

- A9. A painter holds a paint brush, of mass m , against the ceiling by applying a vertical force of magnitude F . The magnitude of the normal force of the ceiling on the brush is
- (A) $F + m$ (B) $F - m$ (C) $F - mg$
 (D) $F + mg$ (E) 0

The net force on the paint brush in the vertical direction is zero. Choosing up to be the positive vertical direction, the forces on the paint brush are $+F$, $-mg$ and $-n$. $+F - mg - n = 0$, so $n = F - mg$. (C)

- A10. A person is holding a stone of mass m in her hand. The stone is initially at rest. She then throws the stone straight up with a velocity v . What is the net work done on the stone from the moment when she starts accelerating it to throw it upward until it reaches maximum height h ?
- (A) $+mgh$ (B) 0 (C) $-mgh$ (D) $-\frac{1}{2}mv^2$ (E) $+\frac{1}{2}mv^2$

The stone is initially at rest in the person's hand, and is again at rest when it reaches maximum height. Therefore, there is no change in the kinetic energy of the stone, and therefore no net work is done on it. (B)

- A11. A mass tied to the end of a string swings from its highest point down to its lowest point along a semi-circular trajectory. Let W_g , W_T and W_a represent work done by gravity, tension, and air resistance, respectively. Which one of the following statements is correct?
- (A) $W_g > 0, W_T = 0, W_a > 0$ (B) $W_g > 0, W_T > 0, W_a < 0$
 (C) $W_g = 0, W_T = 0, W_a < 0$ (D) $W_g < 0, W_T = 0, W_a < 0$
 (E) $W_g > 0, W_T = 0, W_a < 0$

As the mass swings from high to low, its height above an arbitrary reference is decreasing, and therefore its gravitational potential energy is decreasing. Therefore, the gravitational force is doing positive work on the mass. Since the mass is moving along a semi-circular trajectory, the tension in the string is perpendicular to the motion, and therefore does no work. The air resistance force opposes the motion of the mass, so it does negative work. (E)

- A12. An object on a frictionless surface is pushed against a horizontal ideal spring, so that the spring is compressed a distance d . The object is released, and it has a kinetic energy of KE_1 when it loses contact with the spring. The object is then pushed against the spring so that it is now compressed a distance of $2d$. Which one of the following expressions is correct for the kinetic energy, KE_2 , of the object when it loses contact with the spring?

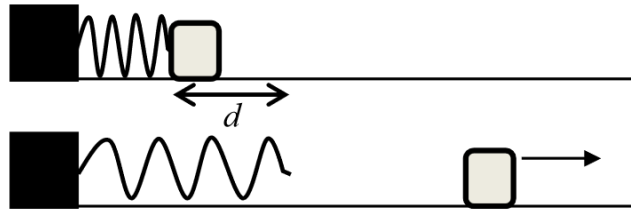

- (A) $KE_2 = 2KE_1$ (B) $KE_2 = 4KE_1$ (C) $KE_2 = KE_1$ (D) $KE_2 = 8KE_1$ (E) $KE_2 = 1.41KE_1$

Since the object is moving along a horizontal frictionless surface, mechanical energy is conserved and there is no change in the object's gravitational potential energy. Therefore, $KE_i + PE_{spring,i} = KE_f + PE_{spring,f}$. So, $0 + \frac{1}{2}kd^2 = KE_1 + 0 \Rightarrow KE_1 = \frac{1}{2}kd^2$ When the spring is compressed a distance of $2d$, $0 + \frac{1}{2}k(2d)^2 = KE_2 + 0 \Rightarrow KE_2 = 4(\frac{1}{2}kd^2) = 4KE_1$ (B)

PART B

WORK OUT THE ANSWERS TO THE FOLLOWING PART B QUESTIONS.

BEFORE SCRATCHING ANY OPTIONS, BE SURE TO DOUBLE-CHECK YOUR LOGIC AND CALCULATIONS.

YOU MAY FIND IT ADVANTAGEOUS TO DO AS MANY OF THE PARTS OF A QUESTION AS YOU CAN BEFORE SCRATCHING ANY OPTIONS.

WHEN YOU HAVE AN ANSWER THAT IS ONE OF THE OPTIONS AND ARE CONFIDENT THAT YOUR METHOD IS CORRECT, SCRATCH THAT OPTION ON THE SCRATCH CARD. IF YOU REVEAL A STAR ON THE SCRATCH CARD THEN YOUR ANSWER IS CORRECT (FULL MARKS, 2/2).

IF YOU DO NOT REVEAL A STAR WITH YOUR FIRST SCRATCH, TRY TO FIND THE ERROR IN YOUR SOLUTION. IF YOU REVEAL A STAR WITH YOUR SECOND SCRATCH, YOU RECEIVE 1.2 MARKS OUT OF 2.

REVEALING THE STAR WITH YOUR THIRD, FOURTH, OR FIFTH SCRATCHES DOES NOT EARN YOU ANY MARKS, BUT IT DOES GIVE YOU THE CORRECT ANSWER.

YOU MAY ANSWER ALL FOUR PART B QUESTION GROUPINGS (1-4, 5-8, 9-12, AND 13-16) AND YOU WILL RECEIVE THE MARKS FOR YOUR BEST 3 GROUPINGS.

USE THE PROVIDED EXAM BOOKLET FOR YOUR ROUGH WORK.

Grouping B1-B4

An athlete stands with his hand outstretched 7.00 m above the bottom of a cliff and throws a ball directly upward. After 3.40 s, the ball falls past its initial position. Eventually the ball lands at the bottom of the cliff. We ignore air resistance and choose the +y direction to be upward.

B1. Which one of the following graphs best represents the acceleration versus time graph for the motion of the ball from just after it is released until just before it hits the bottom of the cliff?

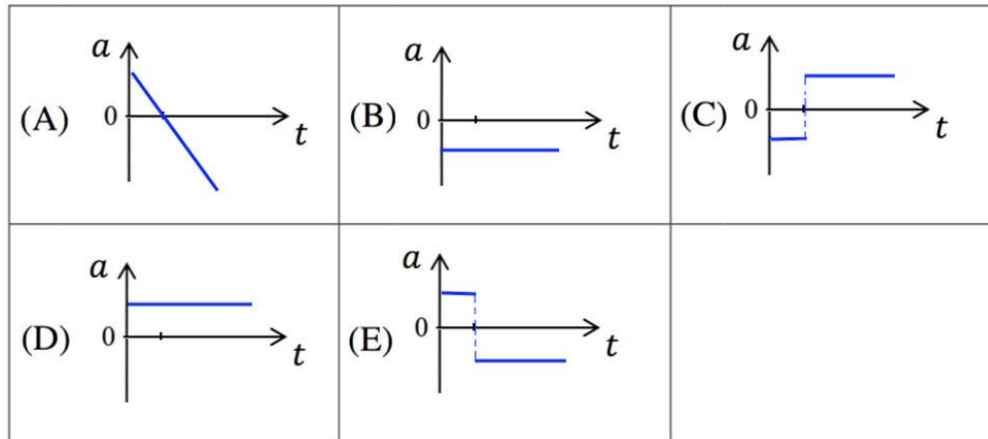

The acceleration is constant at -9.80 m/s^2

B2. Calculate the velocity of the ball at the instant it has left the athlete's hand.

Ignoring air resistance, when the ball returns to its initial position it will be moving with the same speed, but in the opposite direction

$$v_y = v_{oy} + a_y t \Rightarrow -v_{oy} = v_{oy} + a_y t \Rightarrow -2v_{oy} = a_y t \Rightarrow v_{oy} = -\frac{a_y t}{2}$$

$$v_{oy} = -\frac{(-9.80 \text{ m/s}^2)(3.40 \text{ s})}{2} = 16.7 \text{ m/s}$$

B3. Calculate the velocity of the ball just before it reaches the bottom of the cliff.

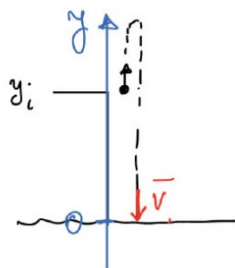

$$v_y^2 = v_{oy}^2 + 2a_y \Delta y \Rightarrow v_y = \sqrt{v_{oy}^2 + 2a_y \Delta y}$$

$$v_y = \pm \sqrt{(16.7 \text{ m/s})^2 + 2(-9.80 \text{ m/s}^2)(-7.00 \text{ m})} = -20.4 \text{ m/s}$$

B4. With respect to the bottom of the cliff, calculate the maximum height that the ball reaches.

At maximum height, the velocity is momentarily zero

Taking the initial position to be maximum height and
the final position to be the bottom of the cliff:

$$v_y^2 = v_{oy}^2 + 2a_y \Delta y \Rightarrow \Delta y = \frac{v_y^2 - v_{oy}^2}{2a_y} = \frac{(-20.4 \text{ m/s})^2 - 0}{2(-9.80 \text{ m/s}^2)} = -21.2 \text{ m}$$

Grouping B5-B8

A launcher is a horizontal distance of $R = 16.0$ m away from a target hung from the branch of a tree. The target is a vertical distance of $h = 4.40$ m above the end of the launcher. A projectile is fired from the launcher, and it is moving horizontally when it hits the target.



B5. Ignoring air resistance, and choosing up as the positive vertical direction, which one of the following velocity versus time graphs best shows the vertical component of the velocity of the projectile from just after leaving the launcher until just before hitting the target?

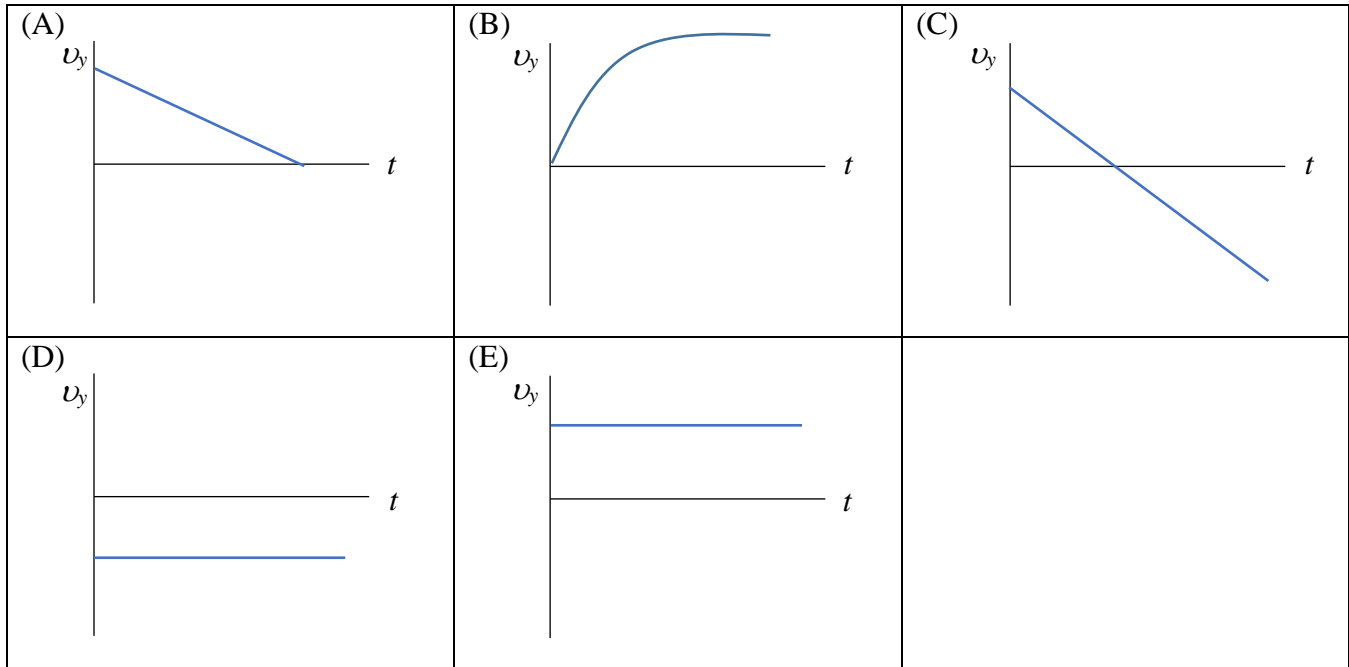

The projectile initially has an upward (positive) component of velocity which decreases to zero when the projectile reaches the target.

B6. Calculate the time for the projectile to reach the target.

$$\begin{aligned}
 v_y^2 &= v_{oy}^2 + 2a_y\Delta y \\
 0 &= v_{oy}^2 + 2a_y\Delta y \\
 v_{oy} &= \sqrt{-2a_y\Delta y} = \sqrt{-2(-9.80 \text{ m/s}^2)(+4.40 \text{ m})} = 9.287 \text{ m/s} \\
 v_y &= v_{oy} + a_y t \\
 t &= \frac{v_y - v_{oy}}{a_y} = \frac{0 - 9.287 \text{ m/s}}{-9.80 \text{ m/s}^2} = 0.9476 \text{ s} = 0.948 \text{ s}
 \end{aligned}$$

B7. Calculate the speed with which the projectile was launched.

$$\begin{aligned}
 v_{oy} &= 9.287 \text{ m/s} \\
 t &= 0.9476 \text{ s} \\
 \Delta x &= v_{ox} t \\
 v_{ox} &= \frac{\Delta x}{t} = \frac{16.0 \text{ m}}{0.9476 \text{ s}} = 16.88 \text{ m/s} \\
 v_o &= \sqrt{v_{ox}^2 + v_{oy}^2} = 19.3 \text{ m/s}
 \end{aligned}$$

B8. Calculate the angle above the horizontal at which the launcher was aimed.

$$\theta_o = \arctan\left(\frac{v_{oy}}{v_{ox}}\right) = \arctan\left(\frac{9.287 \text{ m/s}}{16.88 \text{ m/s}}\right) = 28.8^\circ$$

Grouping B9-B12

Two packing crates of masses $m_1 = 5.00$ kg and $m_2 = 10.0$ kg are connected by a light string that passes over a frictionless pulley as shown in the figure. The 5.00-kg crate lies on an incline of angle $\theta = 40.0^\circ$. The coefficient of kinetic friction between the 5.00-kg crate and the inclined surface is 0.200.

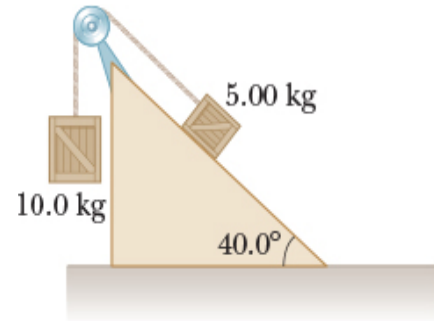

B9. Which one of the following free-body diagrams best represents the forces acting on the 5.00-kg crate?

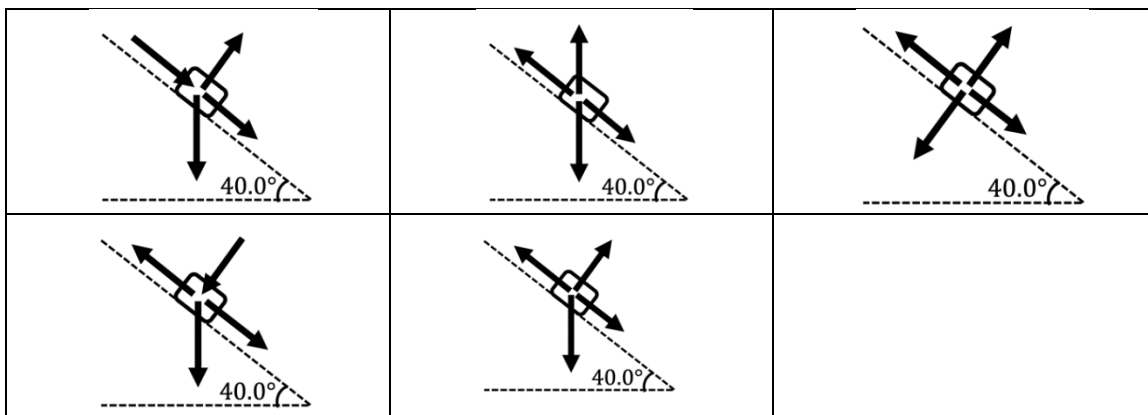

The forces acting on the 5.00-kg crate are the weight force vertically down, the normal force perpendicular to and away from the incline, the tension force up the incline and the frictional force down the incline.

B10. Let a represent the magnitude of the acceleration of the two crates. Which one of the following is the correct formula for the magnitude of the normal force of the incline on the 5.00-kg crate?

- (A) $m_1g \cos\theta$ (B) $m_1g \sin\theta$ (C) $m_1a \cos\theta$
- (D) $\mu_k m_1 a \cos\theta$ (E) $\mu_k m_1 g \sin\theta$

Since the net force perpendicular to the incline is zero, the magnitude of the normal force is equal to the magnitude of the component of the weight that is perpendicular to the incline. $n = m_1g\cos\theta$

B11. Calculate the magnitude of the acceleration of the two crates.

Apply Newton's Second Law separately to each of the crates:

10.0-kg crate (down is positive):

$$\sum F_y = m_2 a \Rightarrow m_2 g - T = m_2 a \Rightarrow m_2 g - m_2 a = T$$

5.00-kg crate (up the plane is +x):

$$\sum F_y = 0 \Rightarrow n_1 - m_1 g \cos \theta = 0 \Rightarrow n_1 = m_1 g \cos \theta$$

$$\sum F_x = m_1 a \Rightarrow -m_1 g \sin \theta + T - f_{k1} = m_1 a$$

Substituting for T :

$$-m_1 g \sin \theta + T - f_{k1} = m_1 a$$

$$-m_1 g \sin \theta + m_2 g - m_2 a - f_{k1} = m_1 a$$

$$-m_1 g \sin \theta + m_2 g - \mu_{k1} m_1 g \cos \theta = (m_1 + m_2) a$$

$$a = \frac{-m_1 g \sin \theta + m_2 g - \mu_{k1} m_1 g \cos \theta}{(m_1 + m_2)}$$

$$a = \left(\frac{(m_2 - m_1 \sin \theta - \mu_{k1} m_1 \cos \theta)}{(m_1 + m_2)} \right) g = 3.93 \text{ m/s}^2$$

B12. Calculate the magnitude of the tension in the string.

$$T = m_2 g - m_2 a = m_2 (g - a)$$

$$T = (10.0 \text{ kg})(9.80 \text{ m/s}^2 - 3.93 \text{ m/s}^2)$$

$$T = 58.7 \text{ N}$$

Grouping B13-B16

A cyclist reaches a section of road that is downhill, then flat, then uphill. The cyclist coasts (i.e. does not apply any power to the pedals). You may assume that the magnitude of the net frictional force on the cyclist is constant, and that the net frictional force is always directed exactly opposite to the cyclist's motion.

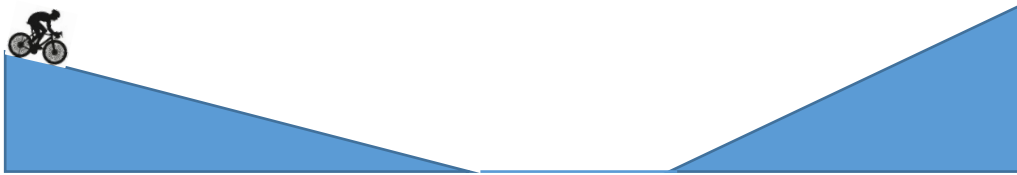

The cyclist has a speed v_1 at the start of the downhill section (at height h above the flat section) and a speed v_2 at the same height on the uphill section. Let W_1 be the work done on the cyclist by gravity on the downhill section and W_2 be the work done on the cyclist by gravity on the uphill section.

B13. Which one of the following statements is correct?

- (A) $v_2 = v_1$ and $|W_2| = |W_1|$
- (B) $v_2 > v_1$ and $|W_2| = |W_1|$
- (C) $v_2 > v_1$ and $|W_2| > |W_1|$
- (D) $v_2 < v_1$ and $|W_2| < |W_1|$
- (E) $v_2 < v_1$ and $|W_2| = |W_1|$

Since the cyclist returns to the same height, gravity does equal amounts of positive and negative work on the cyclist. Because the net frictional force does negative work throughout the motion, the final speed is less than the initial speed.

The downhill section is 465 m long and starts at a height $h = 27.0$ m above the flat section. The flat section is 105 m long. The magnitude of the assumed constant frictional force on the cyclist is 26.0 N. The speed of the cyclist at the start of the downhill section is 37.0 km/h and the mass of the cyclist (+ bike) is 76.0 kg.

B14. Calculate the speed of the cyclist at the start of the flat section.

$$\begin{aligned}
 E_i + W_{nc} &= E_f \\
 KE_i + PE_i + W_{nc} &= KE_f + PE_f \\
 KE_f &= KE_i + PE_i + W_{nc} - PE_f \\
 \frac{1}{2}mv_f^2 &= \frac{1}{2}mv_i^2 + mgh + F_{fric}\Delta x(\cos 180^\circ) - 0 \\
 \frac{1}{2}mv_f^2 &= \frac{1}{2}mv_i^2 + mgh - F_{fric}\Delta x \\
 v_f &= \sqrt{v_i^2 + 2gh - \frac{2F_{fric}\Delta x}{m}} \\
 v_i &= 37.0 \text{ km/h} \times \frac{1000 \text{ m}}{\text{km}} \times \frac{1 \text{ h}}{3600 \text{ s}} = 10.28 \text{ m/s} \\
 v_f &= \sqrt{(10.28 \text{ m/s})^2 + 2(9.80 \text{ m/s}^2)(27.0 \text{ m}) - \frac{2(26.0 \text{ N})(465 \text{ m})}{76.0 \text{ kg}}} = 17.8 \text{ m/s} \\
 v_f &= 17.8 \text{ m/s} \times \frac{1 \text{ km}}{1000 \text{ m}} \times \frac{3600 \text{ s}}{\text{h}} = 64.07 \text{ km/h} = 64.1 \text{ km/h}
 \end{aligned}$$

B15. Calculate the kinetic energy lost by the cyclist between the start and end of the flat section.

$$\begin{aligned}
 E_i + W_{nc} &= E_f \\
 KE_i + PE_i + W_{nc} &= KE_f + PE_f \\
 KE_f - KE_i &= PE_i + W_{nc} - PE_f \\
 \Delta KE &= 0 + F_{fric}\Delta x(\cos 180^\circ) - 0 \\
 \Delta KE &= F_{fric}\Delta x(\cos 180^\circ) \\
 \Delta KE &= -F_{fric}\Delta x = -(26.0 \text{ N})(105 \text{ m}) = -2.73 \times 10^3 \text{ J}
 \end{aligned}$$

B16. Calculate the speed of the cyclist at the end of the flat section.

$$\begin{aligned}
 \Delta KE &= KE_f - KE_i \\
 KE_f &= \Delta KE + KE_i \\
 \frac{1}{2}mv_f^2 &= \Delta KE + \frac{1}{2}mv_i^2 \\
 v_f &= \sqrt{\frac{2\Delta KE}{m} + v_i^2} \\
 v_f &= \sqrt{\frac{2(-2.73 \times 10^3 \text{ J})}{76.0 \text{ kg}} + (17.8 \text{ m/s})^2} = 15.65 \text{ m/s} \\
 v_f &= 15.65 \text{ m/s} \times \frac{1 \text{ km}}{1000 \text{ m}} \times \frac{3600 \text{ s}}{\text{h}} = 56.3 \text{ km/h}
 \end{aligned}$$

END OF EXAMINATION