

UNIVERSITY OF SASKATCHEWAN

Department of Physics and Engineering Physics

Physics 117.3

Physics for the Life Sciences

FINAL EXAMINATION

April 25, 2012

Time: 3 hours

NAME: _____ STUDENT NO.: _____
(Last) Please Print (Given)

LECTURE SECTION (please check):

- 01 B. Zulkoskey
- 02 Dr. J.-P. St. Maurice
- C16 F. Dean

INSTRUCTIONS:

1. This is a closed book examination.
2. The test package includes a test paper (this document), a formula sheet, and an OMR sheet. The test paper consists of 11 pages. **It is the responsibility of the student to check that the test paper is complete.**
3. Only Hewlett-Packard hp 10S or 30S or Texas Instruments TI-30X series calculators, or a calculator approved by your instructor, may be used.
4. Enter your name and student number on the cover of the test paper and check the appropriate box for your lecture section. Also enter your student number in the top right-hand corner of each page of the test paper.
5. Enter your name and STUDENT NUMBER on the OMR sheet.
6. The test paper, the formula sheet and the OMR sheet must all be submitted.
7. None of the test materials will be returned.

ONLY THE FIVE PART B QUESTIONS THAT YOU INDICATE WILL BE MARKED
PLEASE INDICATE WHICH FIVE PART B QUESTIONS ARE TO BE MARKED



QUESTION NUMBER	TO BE MARKED	MAXIMUM MARKS	MARKS OBTAINED
A1-25	<input checked="" type="checkbox"/>	25	
B1	<input type="checkbox"/>	10	
B2	<input type="checkbox"/>	10	
B3	<input type="checkbox"/>	10	
B4	<input type="checkbox"/>	10	
B5	<input type="checkbox"/>	10	
B6	<input type="checkbox"/>	10	
TOTAL		75	

continued on page 2...

PART A

FOR EACH OF THE FOLLOWING QUESTIONS IN PART A, ENTER THE MOST APPROPRIATE RESPONSE ON THE OMR SHEET.

- A1. Which one of the following statements concerning torque is **FALSE**?
- (A) Only the perpendicular component of the force produces a torque.
 - (B) A net external torque causes a change in angular velocity.
 - (C) The magnitude of the torque depends on where the force is applied.
 - (D) The torque due to a force is largest when the direction of the force passes through the axis of rotation.
 - (E) A constant net torque causes a constant angular acceleration.
- A2. Which one of the following statements is **FALSE**?
- (A) Gases and liquids are considered to be fluids because of their ability to flow.
 - (B) A liquid is said to be incompressible if the volume of the liquid changes when the pressure applied to the liquid changes.
 - (C) Gases are easily compressed.
 - (D) Gases and liquids do not have a definite shape.
 - (E) Of the states of matter, the atomic or molecular bonds are generally strongest for solids.
- A3. Consider an object that is at rest, floating in water. Which one of the following statements is **TRUE**?
- (A) The magnitude of the buoyant force acting on the object is greater than the magnitude of its weight.
 - (B) The average density of the object is greater than the density of water.
 - (C) The average density of the object is exactly equal to the density of water.
 - (D) The average density of the object is less than the density of water.
 - (E) The object cannot contain any material that has a density greater than the density of water.
- A4. Consider an object that is completely submerged in an incompressible liquid. Which one of the following graphs correctly shows the dependence of the buoyant force, F , on the object as a function of its depth, d , below the surface of the liquid?

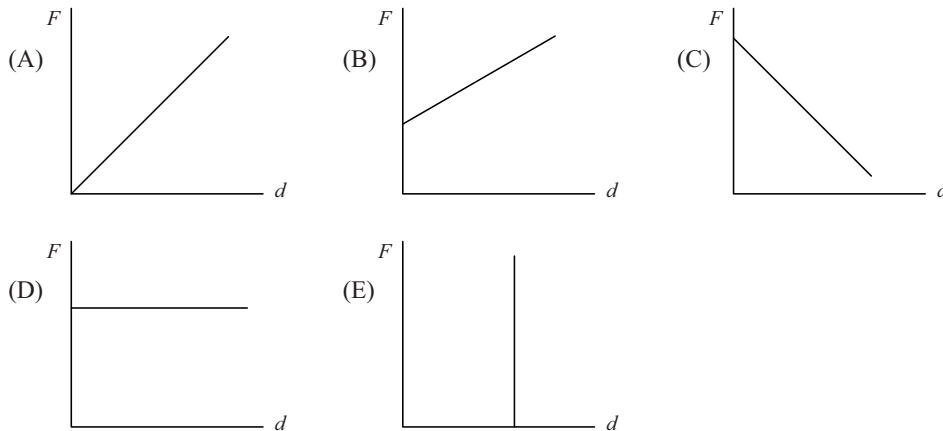

- A5. An object sitting on a horizontal frictionless surface is attached to a horizontal ideal spring. The object is pulled away from its equilibrium position and released. At what position of the object are its displacement from equilibrium, its velocity, and its acceleration all in the same direction?
- (A) the equilibrium position
 - (B) the positions of maximum displacement
 - (C) any position such that the object is moving away from the equilibrium position
 - (D) any position such that the object is moving toward the equilibrium position
 - (E) no position exists where the displacement from equilibrium, the velocity, and the acceleration are all in the same direction

- A6.** A group of people help a friend pull his car out of a ditch by means of a Teflon rope (Young's modulus of $3.7 \times 10^8 \text{ N/m}^2$) that is 12.1 m long and has a cross-sectional area of $1.96 \times 10^{-3} \text{ m}^2$. When the car just begins to move, the tension in the rope is 1190 N. By how much has the rope stretched?
- (A) 1.13 m (B) 3.29 cm (C) 9.12 mm (D) 0.495 mm (E) 1.98 cm

- A7.** The equation of a wave is

$$y(x,t) = (3.5 \text{ cm}) \cos\left(\frac{\pi}{3.0 \text{ cm}} [x - (66 \text{ cm/s})t]\right)$$

The wavelength of this wave is

- (A) 3.0 cm. (B) 1.5 cm. (C) 6.0 cm. (D) 9.0 cm. (E) 3.5 cm.
- A8.** Bats emit ultrasonic waves with a frequency of $1.00 \times 10^5 \text{ Hz}$. What is the wavelength of this wave in air at a temperature of $15.0 \text{ }^\circ\text{C}$? The speed of sound in air at $15.0 \text{ }^\circ\text{C}$ is 340 m/s.
- (A) 3.40 mm (B) 3.34 mm (C) 4.30 mm (D) 4.40 mm (E) 3.00 cm
- A9.** Consider two speakers, separated by a distance d . The speakers produce sound waves of wavelength λ that are identical, coherent, and in phase. Suppose a microphone is placed at a location that is a distance r_1 from one speaker and a distance r_2 from the other speaker. Which one of the following conditions will result in the microphone detecting a large amplitude sound wave?
- (A) $r_1 - r_2 = d$ (B) $r_1 - r_2 = \lambda$ (C) $r_1 - r_2 = d + \lambda$
 (D) $r_1 - r_2 = d - \lambda$ (E) $r_1 - r_2 = d\lambda$

- A10.** Rod 1 of length L made of a material with a coefficient of linear expansion α_1 is placed in line with rod 2 of length L made of a material with a coefficient of linear expansion $\alpha_2 = 2\alpha_1$. The temperature of the composite rod of length $L_{\text{tot}} = 2L$ is now increased and its length changes by a total amount ΔL_{tot} . If ΔL_1 is the change in length of rod 1 and ΔL_2 is the change in length of rod 2, which one of the following statements is correct?
- (A) $\Delta L_2 = \Delta L_1$ (B) $\Delta L_2 = \frac{1}{2} \Delta L_1$ (C) $\Delta L_2 = 2 \Delta L_1$
 (D) $\Delta L_2 = \frac{1}{4} \Delta L_1$ (E) $\Delta L_2 = 4 \Delta L_1$

- A11.** One mole of an ideal gas with a volume of 4.00 litres (one litre is 0.001 m^3) and a temperature of $0 \text{ }^\circ\text{C}$ is mixed with one mole of an ideal gas with a volume of 2.00 litres and a temperature of $100 \text{ }^\circ\text{C}$. The volume of the mixture is 6.00 litres. What is the number density N/V of the mixture?
- (A) $1.75 \times 10^{26} \text{ m}^{-3}$ (B) $2.01 \times 10^{26} \text{ m}^{-3}$ (C) $2.66 \times 10^{26} \text{ m}^{-3}$
 (D) $3.21 \times 10^{26} \text{ m}^{-3}$ (E) $3.56 \times 10^{26} \text{ m}^{-3}$

- A12.** A 100-g block of aluminum, initially at 60°C , is dropped into 100 g of water that is initially at 10°C . The final temperature of the aluminum-water system is 20°C . Assuming that no heat was lost from the aluminum-water system, it can be concluded that the specific heat of aluminum, c_{Al} , is related to the specific heat of water, c_{w} , by
- (A) $c_{\text{Al}} = \frac{1}{2} c_{\text{w}}$ (B) $c_{\text{Al}} = \frac{1}{4} c_{\text{w}}$ (C) $c_{\text{Al}} = c_{\text{w}}$ (D) $c_{\text{Al}} = 2 c_{\text{w}}$ (E) $c_{\text{Al}} = 4 c_{\text{w}}$

- A13.** A window conducts power P from a house to the cold outdoors. What power is conducted through a window of half the area and half the thickness?
- (A) $4P$ (B) $2P$ (C) P (D) $\frac{1}{2} P$ (E) $\frac{1}{4} P$

- A14.** Which one of the following statements concerning the image formed by a single diverging lens is **TRUE**?
- (A) If the object distance is greater than the focal length then the image is virtual, upright, and enlarged.
 (B) If the object distance is less than the focal length then the image is virtual, upright, and enlarged.
 (C) If the object distance is greater than the focal length then the image is real and inverted.
 (D) The image is always virtual, upright, and smaller than the object.
 (E) If the object distance is less than the focal length then the image is real and inverted.

- A21.** In a double slit experiment with coherent light, the intensity of the light reaching the centre of the screen from one slit alone is I_0 and the intensity of the light reaching the centre from the other slit alone is $9I_0$. When both slits are open, what is the intensity of the light at the interference minima nearest the centre? The slits are very narrow.
- (A) $8I_0$ (B) I_0 (C) $2I_0$ (D) $3I_0$ (E) $4I_0$
- A22.** How does the composition of the daughter nucleus compare to that of the parent nucleus following an alpha decay?
- (A) The atomic number has decreased by 2 and the mass number has decreased by 2.
(B) The atomic number has decreased by 4 and the mass number has decreased by 2.
(C) The atomic number has decreased by 2 and the neutron number has decreased by 4.
(D) The atomic number has decreased by 4 and the neutron number has decreased by 2.
(E) The atomic number has decreased by 2 and the neutron number has decreased by 2.
- A23.** What is the symbol for the nuclide with 46 protons and 92 neutrons?
- (A) ${}_{46}^{96}\text{Pd}$ (B) ${}_{92}^{138}\text{U}$ (C) ${}_{46}^{138}\text{Pd}$ (D) ${}_{92}^{46}\text{U}$ (E) ${}_{138}^{46}\text{Pd}$
- A24.** Radioactive ${}_{83}^{215}\text{Bi}$ decays into ${}_{84}^{215}\text{Po}$. Which of these particles is released in the decay?
- (A) a proton (B) an electron (C) a positron (D) a neutron (E) an α particle
- A25.** The activity of a radioactive sample (with a single radioactive nuclide) decreases to one eighth its initial value in a time interval of 96 days. What is the half-life of the radioactive nuclide?
- (A) 8 days (B) 12 days (C) 16 days (D) 24 days (E) 32 days

PART B

ANSWER FIVE PART B QUESTIONS AND INDICATE YOUR CHOICES ON THE COVER PAGE.

IN EACH OF THE PART B QUESTIONS ON THE FOLLOWING PAGES, GIVE THE COMPLETE SOLUTION AND ENTER THE FINAL ANSWER IN THE BOX PROVIDED. THE ANSWERS MUST CONTAIN THREE SIGNIFICANT FIGURES AND THE UNITS MUST BE GIVEN. SHOW AND EXPLAIN YOUR WORK – NO CREDIT WILL BE GIVEN FOR ANSWERS ONLY. EQUATIONS NOT PROVIDED ON THE FORMULAE SHEET MUST BE DERIVED. USE THE BACK OF THE PREVIOUS PAGE FOR YOUR ROUGH WORK.

- B1.** A uniform trap door, mass 5.00 kg, is being held at an angle of 60.0° with the horizontal by a cable, as shown in the diagram. The cable is perpendicular to the door and is attached at a distance of $\frac{3}{4}\ell$ from the frictionless hinge, where ℓ is the length of the trap door.

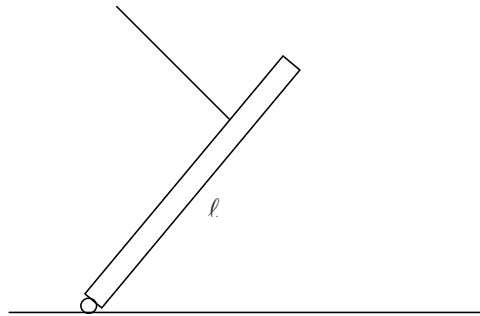

- (a) Calculate the tension in the cable. (5 marks)

- (b) If the cable breaks, calculate the angular velocity of the trap door, in terms of ℓ , just before it is horizontal. (5 marks)

- B2.** In a classroom demonstration, a speaker was mounted on the end of a 50-cm-long arm and rotated in a horizontal circle at a constant angular speed of 75.0 rpm. The speaker emitted sound at a constant frequency of 441 Hz. The speed of sound was 343 m/s.

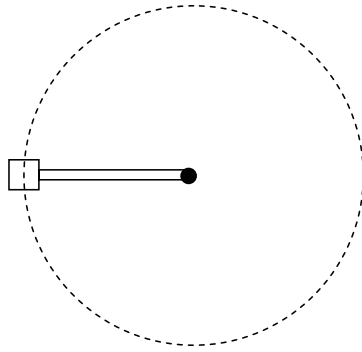

- (a) Calculate the range of sound frequencies heard by the students in the classroom. (6 marks)

- (b) If the speaker produced sound energy at a rate of 4.25 J/s, calculate the sound intensity level (in dB) at a distance of 6.50 m from the speaker. (4 marks)

B3. The drawing shows a cylinder fitted with a piston that has a mass m_1 of 0.500 kg and a radius of 2.50×10^{-2} m. The top of the piston is open to the atmosphere. The seal between the piston and the cylinder is frictionless but airtight – the piston can move freely in the cylinder but no air can escape from or enter the cylinder. A rope of negligible mass is attached to the piston and passes over two massless pulleys. The other end of the rope is attached to a block of mass m_2 of 9.50 kg. m_2 is initially held at rest and the pressure in the cylinder beneath the piston is initially atmospheric pressure. The pressure in the cylinder is allowed to change through compression (or expansion) when m_2 is released.

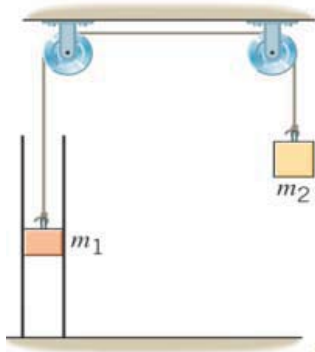

- (a) In the space beside the diagram above, draw free body diagrams for the masses after m_2 has been released from rest. (3 marks)
- (b) When the masses have reached their equilibrium positions, use the fact that the tension in the rope is constant to determine the pressure below mass m_1 , i.e. the pressure inside the cylinder below the piston. (4 marks)

- (c) If the bottom of mass m_1 was 10.0 cm above the floor of the cylinder before the masses started to move, how high will the bottom of the mass be after the masses have stopped moving? Assume that the temperature in the cylinder has been held equal to the outside temperature. (3 marks)

B4. You are tasked with making a microscope with a magnification of -200 using a converging lens with a focal distance of 1.50 cm for the objective. The tube length (that is, the distance between the focal points of the two lenses) is 30.0 cm. The microscope will be used for relaxed-eye viewing.

- (a) Draw a diagram of the microscope showing the position of the object, the position of the objective lens, the tube length, and the position of the eyepiece. Use the symbols f_o for the focal distance of the objective, f_e for the focal distance of the eyepiece, and L for the tube length. Also show where the eye of the observer will be located. (3 marks)



- (b) Determine the position p of the object and from it the lateral magnification of the objective lens if the objective image is to be located at the focus of the eyepiece. (4 marks)

p :

m :

- (c) From the requirement that the total angular magnification is -200 , determine what the focal distance of the eyepiece will have to be. Assume the near point of the observer to be 25.0 cm. (3 marks)

- B5.** The wavelength of the laser beam used in a compact disc player is 580 nm. Suppose that a diffraction grating produces a first-order tracking beam that is a distance $y = 0.625$ mm from the central bright fringe at a distance of $L = 3.00$ mm from the grating as shown in the diagram below.

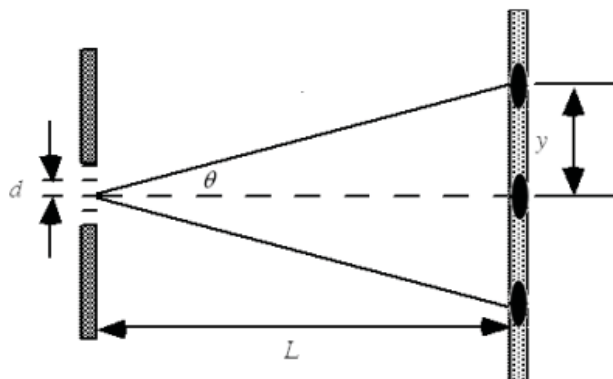

- (a) Calculate the angle θ . (3 marks)

- (b) Calculate the slit separation, d , for the grating. If you did not obtain an answer for (a), use a value of 13.0° . (4 marks)

- (c) Calculate the number of lines per mm for the diffraction grating. If you did not obtain an answer for (b), use a value of 2.60×10^{-3} nm. (3 marks)

B6. One possible fission reaction for ^{235}U is $n + ^{235}_{92}\text{U} \rightarrow ^{141}_{56}\text{Ba} + ^{92}_{36}\text{Kr} + ?n$

where ? represents one or more neutrons.

(a) How many neutrons are released in the fission reaction? (2 marks)

(b) From the graph shown below, you can read the approximate binding energies per nucleon for the three nuclides involved. Use that information to estimate the total energy released by the fission reaction. (4 marks)

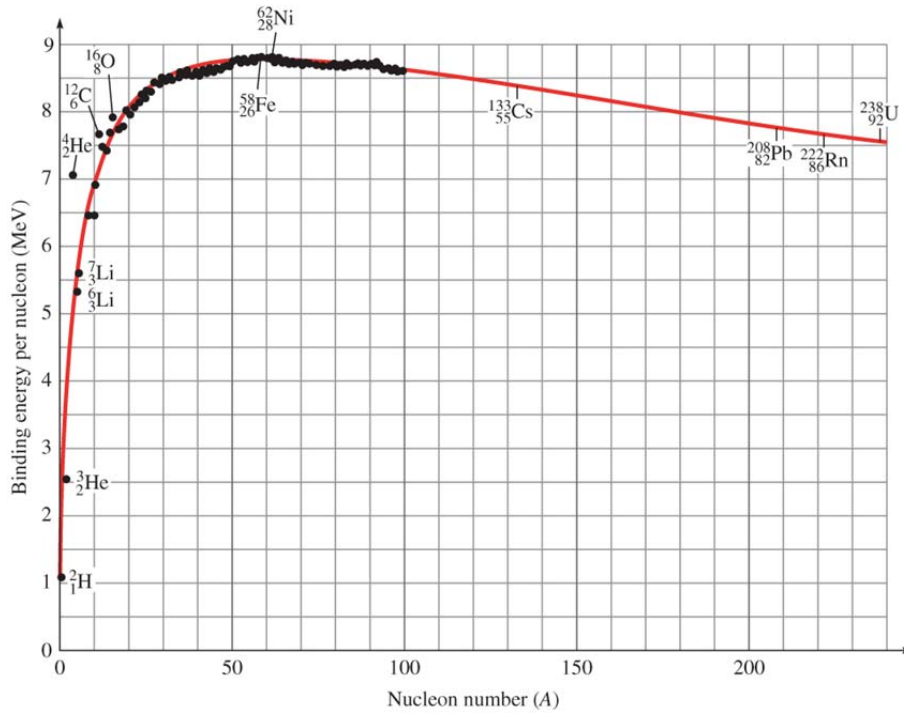

(c) Using your answer from (b), approximately what fraction of the rest energy of the ^{235}U nucleus is released by this reaction? (The rest energy is the energy-equivalent of the mass of the ^{235}U nucleus.) If you did not obtain an answer for (b), use a value of 190 MeV. (4 marks)